

Safety-interlocked Power Outlet

32A 480VAC

Catalog No: R32-480-30-65SND-SP

Item No: 1700-59AN

Features



- UL Listed safety-interlocked power outlet containing an integral 30A circuit breaker
- Actuator rod allows user to turn on/off and reset tripped breaker
- UL Listed circuit breaker rated 65kAIC @ 480VAC provides short circuit & over current protection
- 2-piece receptacle with polyamide receptacle housing and high temp rynite® insert
- Spring-loaded snap cover protects receptacle when not in use
- Mechanically-interlocked replacement outlet for use in ESL single gang or multi gang assemblies to power ISO reefer containers

Drawing

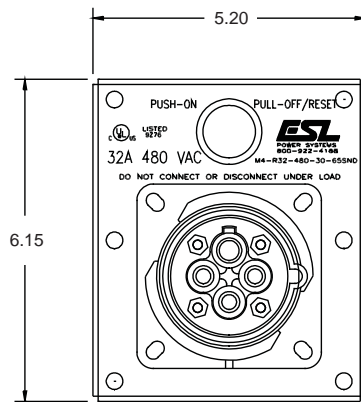

FRONT VIEW

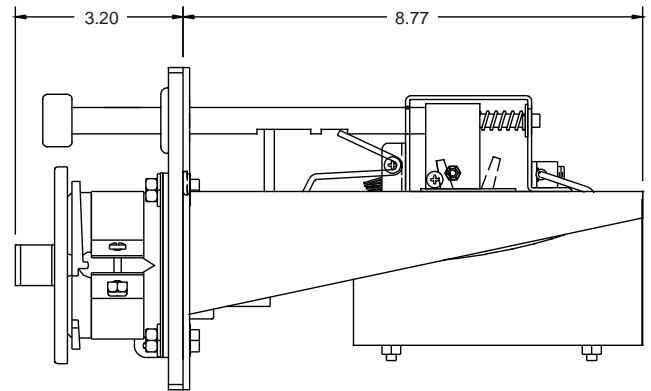

SIDE VIEW

Approvals

- UL/cUL Listed outlet
- UL 489 Listed / CSA certified molded case circuit breaker

Specifications

Catalog No: R32-480-30-65SND-SP
 Item No: 1700-59AN

Ratings

Receptacle	32A 480VAC (380/440VAC 50/60 Hz) per IEC 60309-1 & -2, CEE-17 3h
Circuit breaker	3P molded case, 30A trip / 65,000AIC @ 480VAC, other trip and AIC ratings available - contact factory
Terminals	Installer wires direct to circuit breaker: (3) phase & (1) ground pressure type screw terminals, Phases: #14 AWG - 1/0 (2-54mm) wire range, Ground: #14 - #2 AWG (2-34mm) wire range
Environmental	Type 4X when housed in ESL single gang or multi gang assembly

Materials

Stainless steel	Frame, faceplate, on/off rod, interlock mechanism, contact terminal screws & spring, snap cover and all fasteners
Nickel plated brass	Contact sleeves
Rynite®	Receptacle insert
Polyamide	Receptacle housing
GP Acetal	Knob, rod seal holder
Neoprene (CR)	Gaskets, cover seals
Buna-N (Nitrile/NBR)	O-rings

Packaging

Product weight	6 lbs.
Shipping weight	7 lbs.
Shipping dimensions	16in x 8in x 8in

Replacement Parts

Description	Item No.	Description	Item No.
Stainless steel snap cover assembly	1500-01	Ground sleeve kit	4016-03
Receptacle complete housing with insert, contact sleeve & ground assembly	4010-75	Phase sleeve kit (set of 3)	4015-01
Insert, contact sleeve & ground assembly	4010-76	Circuit breaker kit	4020-17