

Reverse Service Safety-interlocked Power Outlet

200A 480VAC

Catalog No: R200R-480-200-65MEW-SP

Item No: 1700-99AAR

Features



- UL Listed safety-interlocked power outlet containing an integral 200A circuit breaker
- Actuator rod allows user to turn on/off and reset tripped breaker
- UL Listed circuit breaker rated 65kAIC @ 480VAC provides short circuit & over current protection
- Furnished with reverse service Appleton® receptacle AP20034ERS
- Snap cover protects receptacle when not in use
- Electrically-interlocked replacement outlet for use in ESL single gang or multi gang assemblies
- Mates with Appleton® AP20034ERS female plug

Drawing

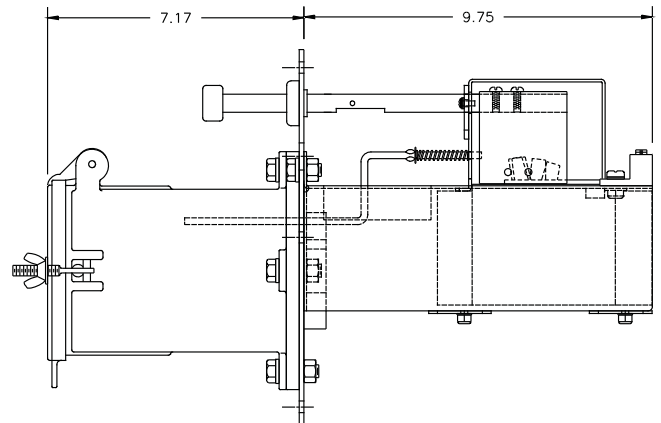
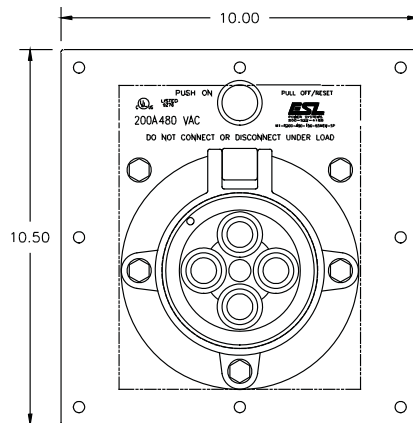

Approvals

- UL/cUL Listed outlet
- UL 489 Listed / CSA certified molded case circuit breaker

Specifications

Catalog No: R200R-480-200-65MEW-SP
 Item No: 1700-99AAR

Ratings

Receptacle	200A 480VAC (380/440VAC 50/60 Hz)
Circuit breaker	3P molded case, 200A trip / 65,000AIC @ 480VAC, other trip and AIC ratings available - contact factory
Terminals	Installer wires direct to circuit breaker: (3) phase & (1) ground pressure type screw terminals, Phases: #4 AWG - 4/0 (21 - 107mm ²) wire range, Ground: (1) #14 AWG - 2/0 (2 - 67mm ²) wire range
Environmental	Type 4X when housed in ESL single gang or multi gang assembly

Materials

Stainless steel	Frame, faceplate, on/off rod, rod seal, interlock mechanism, contact terminal screws & spring, snap cover and all fasteners
Nickel plated brass	Contact sleeves
Glass-filled polyester	Contact carrier
Copper-free aluminum	Receptacle housing, snap cover
Neoprene (CR)	Gaskets, cover seals

Packaging

Product weight	24 lbs.
Shipping weight	27 lbs.
Shipping dimensions	18in x 16in x 12in

Replacement Parts

Description	Item No.	Description	Item No.
Circuit breaker kit	4020-56	Receptacle complete housing with insert, contact sleeve & ground assembly	4010-XX