

Flanged Connector

50A 240VAC
 Catalog No: CF50-240-SP
 Item No: 1910-02

Features



- Heavy-duty design for intermodal applications, shipboard, rail or over-road
- For use as an in-line connector or can be equipment-mounted using extra long bolts provided
- Developed specifically for the severe punishment of underslung gen-set applications, mounted on gen-set or directly to trailer chassis
- Stainless steel self-aligning snap cover
- Watertight screw cover optional

Drawing

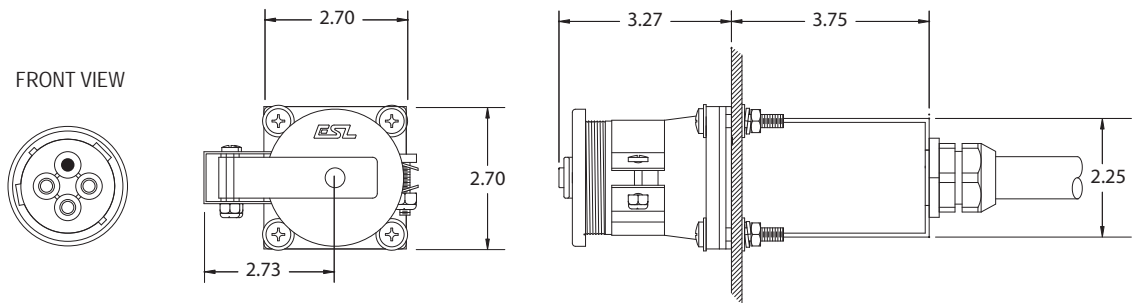

Specifications

Catalog No: CF50-240-SP
Item No: 1910-02

Ratings

Electrical	50A 240VAC pin & sleeve 3 phase 3 wire + ground
Cable range	0.71-0.99in (18 - 25mm) diameter
Environmental	Watertight
Terminals	(3) Phase & (1) ground pressure type 1/4-28 screw terminals (2 per pole) accept #8 - #10 AWG (8-5mm ²) 4 conductor cord

Materials

Stainless steel	Rear housing, terminal screws, snap cover and all fasteners
Thermoplastic Polyester (PET)	Receptacle housing /insert
Nickel plated brass	Contact sleeves
Polychloroprene	Gaskets
Buna-N (Nitrile/NBR)	O-rings
Neoprene	Gaskets

Packaging

Approx. product weight	4.5 lbs. (ea)
Approx. shipping weight	45 lbs. (carton of 10)
Approx. shipping dimensions	17in x 8in x 8in (carton of 10)