

Transformer Cart

15KVA 480:240 Autotransformer
 Catalog No: XK32-480-30-240-SP
 Item No: 2203-98-01A

Features



- 3-phase self contained, portable unit; safely connect 30A 240V reefers to 32A 480V power outlets
- Powder-coated stainless steel enclosure resists corrosion & abuse
- Contains UL Listed safety-interlocked module #1700-34A containing an integral 30A circuit breaker
- Handles, wheels and lashing points allow maximum flexibility for shipboard or landside use

Drawing

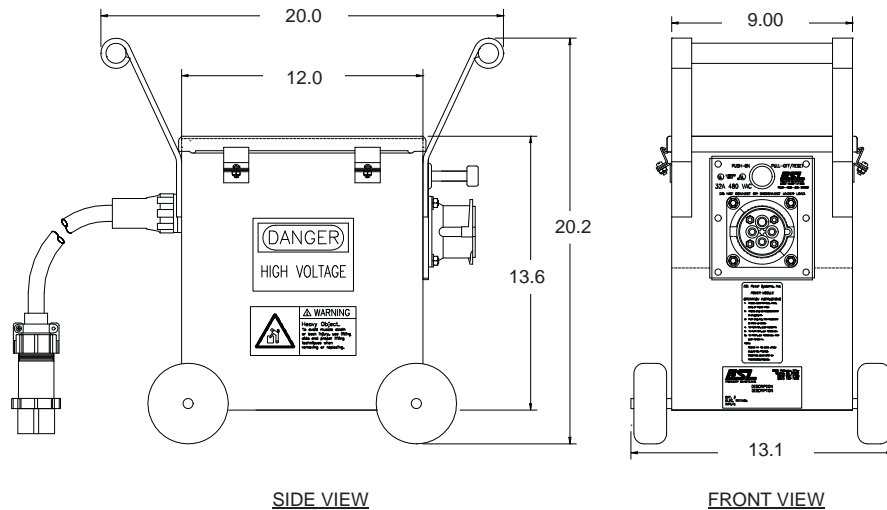

Approvals

- UL Listed receptacle
- UL 489 Listed / CSA certified molded case circuit breaker
- UL Listed plug

Specifications

Catalog No: XK32-480-30-240-SP

Item No: 2203-98-01A

Ratings

Transformer	15KVA 3Ø 60Hz (12.5 KVA 50Hz)
Nominal voltage	2:1, 440-480: 220-240 VAC
Secondary circuit protection	50A trip, 65,000AIC @ 240VAC
Receptacle	30A 240VAC (380/440VAC 50/60Hz) 3 phase 3 wire + ground
Connectors	Watertight male plug E334MP, 30A 250VAC

Materials

Powder coated type 304 stainless steel	Enclosure
Varnish potting compound	Encapsulant
Copper, steel; epoxy sealed	Transformer

Packaging

Approx. product weight	148 lbs.
Approx. shipping weight	153 lbs.