

# 8-Gang Reefer Outlet Pedestal Mount Assembly

**32A 480VAC**

(32A 380/440VAC per IEC 60309-1 & -2)

Catalog No: E8-R32-480-30-65SNPPY8-SP

Item No: 2209-38C

## Features



- UL Listed 8-gang assembly complete with UL Listed safety-interlocked outlets each containing an integral 30A circuit breaker
- Type 4X enclosure manufactured from 14GA seam-welded stainless steel powder-coated texture gray (RAL7038)
- (8) safety-interlocked ESL 32A outlets #1700-59ANPPY8 factory wired to power distribution block (PDB)
- UL Listed circuit breaker rated 65kAIC @ 480VAC provides short circuit & overcurrent protection at each outlet
- Each outlet's actuator rod allows user to turn on/off and reset tripped breaker
- Gasketed bolt-on access cover with drip shield

## Drawing

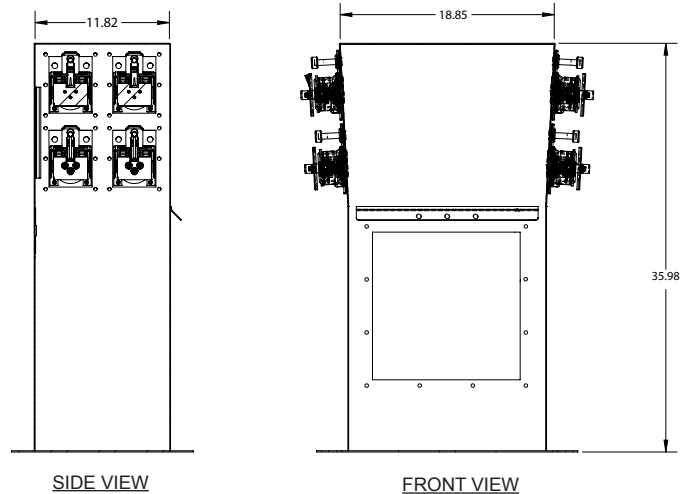

## Approvals

- UL/cUL Listed modules and assembly
- UL 489 Listed / CSA certified molded case circuit breakers

## Specifications

Catalog No: E8-R32-480-30-65SNPPY8-SP  
Item No: 2209-38C

### Ratings

8-Gang assembly	240A 480VAC (440/480VAC 50/60hz) 3 phase 3 wire + ground, 65kAIC RMS symmetrical amps
Receptacles	32A 480VAC (380/440VAC 50/60 Hz) per IEC 60309-1 & -2
Circuit breakers	30A trip, 65,000AIC @ 480VAC, other trip and AIC ratings available - contact factory
Environmental	Type 4X/IP67
PDB terminals	PDB accepts crimp lug or mechanical lug with 1-3/4" spacing

### Materials

Stainless steel	Enclosure, access cover, outlet frames, on/off rods, interlock mechanisms, contact terminal screws & springs, snap covers and all fasteners
Aluminum	PDB Lugs
Nickel plated brass	Contact sleeves
Rynite®	Receptacle insert
Polyamide	Receptacle housing
Buna-N (Nitrile/NBR)	O-rings, gaskets, cover seals

### Approximate Weight

Approx. weight	130 lbs.
Approx. shipping weight	135 lbs.

### Replacement Parts

Description	Item No.	Description	Item No.
Safety-interlocked power outlet	1700-59ANPPY8	Circuit breaker	4020-17
Stainless steel snap cover assembly	1500-01	Ground sleeve kit	4016-03
Receptacle insert contact sleeve assembly	4010-76-8	Phase sleeve Kit	4015-01