

## 2-Gang Wall Mount Assembly

### 60A 480VAC

(60A 380/440VAC per IEC 60309-1 & -2)

Catalog No: E2-R60-480-50-22SSD-SP

Item No: 2214-45

#### Features



- UL Listed 2-gang assembly complete with UL Listed safety-interlocked outlets each containing an integral 50A circuit breaker
- Type 4X enclosure manufactured from 14GA seam-welded stainless steel (powder-coated grey)
- (2) safety-interlocked ESL 60A outlets #1700-55A factory wired to power distribution block (PDB)
- UL Listed circuit breaker rated 22kAIC @ 480VAC provides short circuit & overcurrent protection at each outlet
- Each outlet's actuator rod allows user to turn on/off and reset tripped breaker
- PDB accepts incoming cable range of (1) #14AWG - 2/0 per phase line side
- Gasketed bolt-on access cover with drip shield
- Mates with ESL E634MP4 male plug

#### Drawing

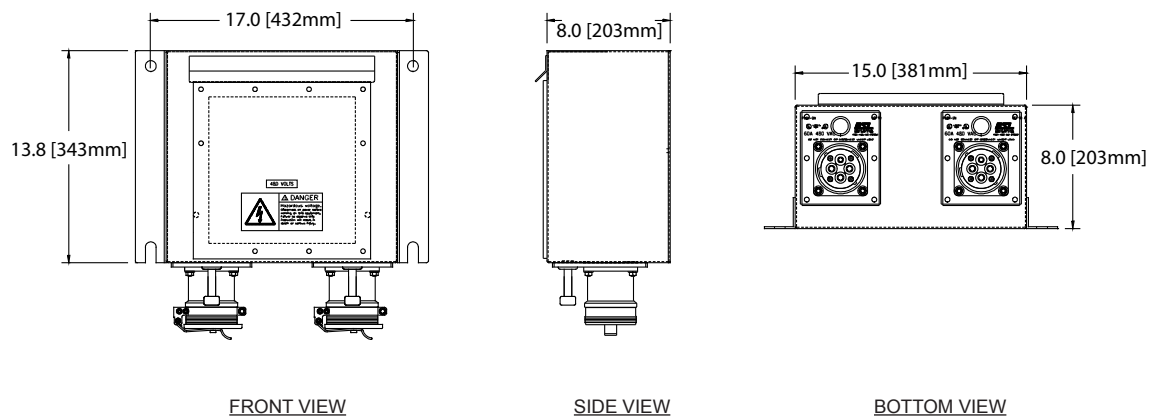

#### Approvals

- UL/cUL Listed modules and assembly
- UL 489 Listed / CSA certified molded case circuit breakers

## Specifications

Catalog No: E2-R60-480-50-22SSD-SP

Item No: 2214-45

### Ratings

2-Gang assembly	100A 480VAC (380 - 480VAC 50/60hz) 3 phase 3 wire + ground, 22kAIC RMS symmetrical amps
Receptacles	60A 480VAC (380/440VAC 50/60 Hz) per IEC 60309-1 & -2
Circuit breakers	50A trip, 22,000AIC @ 480VAC, other trip and AIC ratings available - contact factory
Environmental	Type 4X/IP66
PDB terminals	Line side terminal accepts (1) #14 - 2/0 per phase Ground terminal accepts (1) #14 - 2/0

### Materials

Stainless steel	Enclosure, access cover, outlet frames, on/off rods, interlock mechanisms, contact terminal screws & springs, snap covers and all fasteners
Aluminum	PDB Lugs
Nickel plated brass	Contact sleeves
Rynite®	Receptacle insert
Polyamide	Receptacle housing
Buna-N (Nitrile/NBR)	O-rings, gaskets, cover seals

### Approximate Weight

Approx. weight	53 lbs.
Approx. shipping weight	63 lbs.

### Replacement Parts

Description	Item No.	Description	Item No.
Safety-interlocked power outlet	1700-55A	Circuit breaker	4020-06
Stainless steel snap cover assembly	1501-35	Ground sleeve kit	4016-12
Receptacle insert contact sleeve assembly	4010-62	Phase sleeve kit	4015-04