

Wall-mounted Dual Voltage Transformer

15KVA 480:240 Autotransformer
 Catalog No: XKD-480/240-30/50-22SD/65SC-SP
 Item No: 2219-37A

Features



- 3-phase self contained, wall-mounted unit; safely connects 32A 480V or 30A 240V reefer power outlets
- Allows either 480V or 240V outlet to be energized at one time
- Dual voltage safety-interlocked module #1701-65A containing integral 30A & 50A circuit breakers
- Powder-coated stainless steel enclosure resists corrosion & abuse

Drawing

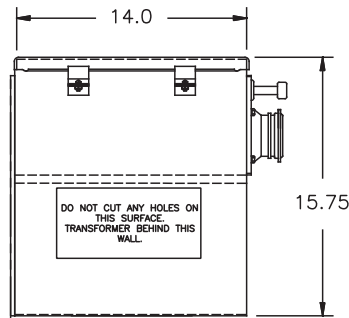

SIDE VIEW

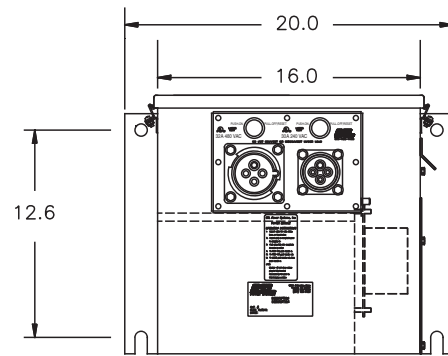

FRONT VIEW

Approvals

- UL 489 Listed / CSA certified molded case circuit breaker

Specifications

Catalog No: XKD-480/240-30/50-22SD/65SC-SP

Item No: 2219-37A

Ratings

Transformer	15KVA 3Ø 60Hz (12.5 KVA 50Hz)
Nominal voltage	1:2, 220-240: 440-480 VAC
Secondary circuit protection	(1) 30A trip, 22,000AIC @ 480VAC (1) 50A trip, 65,000AIC @ 240VAC
Receptacle	(1) 32A 480VAC (380/440VAC 50/60Hz) 3 phase 3 wire + ground (1) 30A 240VAC (380/440VAC 50/60Hz) 3 phase 3 wire + ground

Materials

Powder coated type 304 stainless steel	Enclosure
Varnish potting compound	Encapsulant
Copper, Steel; Epoxy Sealed	Transformer

Packaging

Approx. product weight	178 lbs.
Approx. shipping weight	183 lbs.