

eTRUconnect® MC Series 1-Gang Refrigerated Truck/Trailer Shore Power Station

50A 208VAC 3P 4W + G
 Catalog No: E1-R50-208-50-65SCPP-SPL
 Item No: 2223-73BALG

Features



- UL Listed 1-gang power station for energizing refrigerated truck/trailers, complete with safety-interlocked module containing an integral 50A circuit breaker
- Type 4X enclosure manufactured from 14GA seam-welded stainless steel powder-coated texture light green (RAL 6018)
- Factory installed safety-interlocked ESL module #1700-37APP-208
- UL Listed circuit breaker rated 65kAIC @ 208VAC provides short circuit & overcurrent protection
- Furnished with “Power On” red neon indicator light and “Power Available” amber neon indicator light
- Actuator rod allows user to turn on/off and reset tripped breaker
- Universal mounting – requires (4) fasteners
- Gasketed bolt-on access cover
- Furnished with (1) set of stainless steel cable management brackets
- Module lock-out device
- Factory wired complete to terminal blocks

Drawing

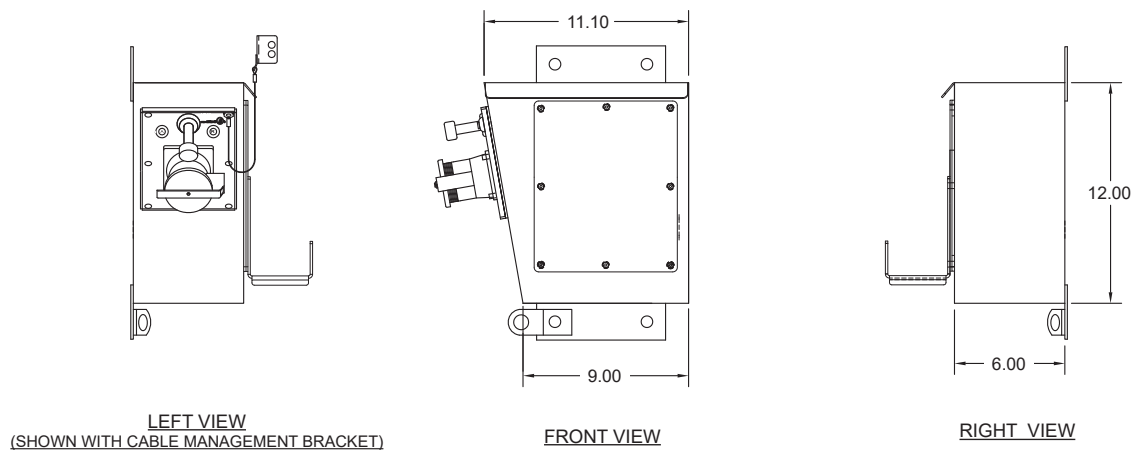

Approvals

- UL/cUL Listed module
- UL/cUL Listed assembly
- UL 489 Listed / CSA certified molded case circuit breaker

Specifications

Catalog No: E1-R50-208-50-65SCPP-SPL
Item No: 2223-73BALG

Ratings

| | |
|-----------------|--|
| Receptacle | 50A 208VAC, 3 phase 3 wire + ground |
| Circuit breaker | 50A trip, 65,000AIC @ 208VAC, other trip and AIC ratings available - contact factory |
| Environmental | Type 4X/IP66 |
| Terminal | Installer wires direct to circuit breaker: (3) phase & (1) ground pressure type screw terminals, Phases: #10 - 1/0 AWG (4-50mm ²) wire range, Ground: #14 - #2 AWG (2-33mm ²) wire range |

Materials

| | |
|----------------------|--|
| Stainless steel | Enclosure, access cover, module frame, on/off rod, interlock mechanism, contact terminal screws & spring, snap cover and all fasteners |
| Nickle plated brass | Contact sleeves |
| Rynite® | Receptacle housing |
| Buna-N (Nitrile/NBR) | O-rings, gaskets, snap cover seal |
| GP Acetal | Knob, rod seal |

Packaging

| | |
|-------------------------|---------|
| Approx. weight | 15 lbs. |
| Approx. shipping weight | 20 lbs. |

Replacement Parts

| Description | Item No. | Description | Item No. |
|-------------------------------------|----------------|---------------------|---------------|
| Safety-interlocked power module | 1700-37APP-208 | Phase sleeve kit | 4015-03 |
| Stainless steel snap cover assembly | 1500-16L | Circuit breaker kit | 4020-06 |
| Replacement receptacle kit | 4010-26 | Ground sleeve kit | 4016-08 |
| Pilot light Red | 1400-46-240 | Pilot light Amber | 1400-46AM-240 |