

# eTRUconnect® MC Series 2-Gang Refrigerated Truck/Trailer Shore Power Station

50A 208VAC 3P 4W + G  
Catalog No: E2-R50-208-50-65SCPP-SPL  
Item No: 2223-73GALG

## Features



- UL Listed 2-gang power station for energizing refrigerated truck/trailers, complete with safety-interlocked module containing an integral 50A circuit breaker
- Provided with (1) GFCI, 20A, 120V duplex receptacle with while-in-use cover
- Type 4X enclosure manufactured from 14GA seam-welded stainless steel powder-coated texture light green (RAL 6018)
- Factory installed safety-interlocked ESL module #1700-37APP-208
- UL Listed circuit breaker rated 65kAIC @ 208VAC provides short circuit & overcurrent protection
- Furnished with “Power On” red neon indicator light and “Power Available” amber neon indicator light
- Actuator rod allows user to turn on/off and reset tripped breaker
- Universal mounting – requires (4) fasteners
- Gasketed bolt-on access cover
- Furnished with (1) set of stainless steel cable management brackets
- Module lock-out device
- Factory wired complete to terminal blocks

## Drawing

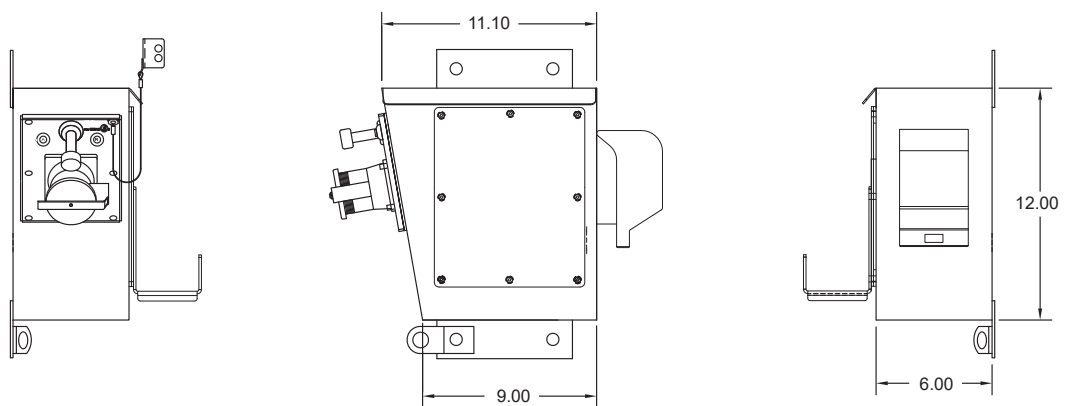

LEFT VIEW  
(SHOWN WITH CABLE MANAGEMENT BRACKET)

FRONT VIEW

RIGHT VIEW

## Approvals

- UL/cUL Listed module
- UL/cUL Listed assembly
- UL 489 Listed / CSA certified molded case circuit breaker

## Specifications

Catalog No: E2-R50-208-50-65SCPP-SPL  
Item No: 2223-73GALG

### Ratings

Receptacle	50A 208VAC, 3 phase 3 wire + ground
Circuit breaker	50A trip, 65,000AIC @ 208VAC, other trip and AIC ratings available - contact factory
Environmental	Type 4X/IP66
Terminal	Installer wires direct to circuit breaker: (3) phase & (1) ground pressure type screw terminals, Phases: #10 - 1/0 AWG (4-50mm <sup>2</sup> ) wire range, Ground: #14 - #2 AWG (2-33mm <sup>2</sup> ) wire range

### Materials

Stainless steel	Enclosure, access cover, module frame, on/off rod, interlock mechanism, contact terminal screws & spring, snap cover and all fasteners
Nickle plated brass	Contact sleeves
Rynite®	Receptacle housing
Buna-N (Nitrile/NBR)	O-rings, gaskets, snap cover seal
GP Acetal	Knob, rod seal

### Packaging

Approx. weight	17 lbs.
Approx. shipping weight	22 lbs.

### Replacement

#### Parts

Description	Item No.	Description	Item No.
Safety-interlocked power module	1700-37APP-208	Phase sleeve kit	4015-03
Stainless steel snap cover assembly	1500-16L	Circuit breaker kit	4020-06
Replacement receptacle kit	4010-26	Ground sleeve kit	4016-08
Pilot light Red	1400-46-240	Pilot light Amber	1400-46AM-240
Duplex GFCI with while-in-use cover	4000-21		