

2-Gang Stainless Steel Enclosure

32A 480VAC

(32A 380/440VAC per IEC 60309-1 & -2)

Catalog No: E2-R32-480-30-35SNQP-SP

Item No: 2267-59AN

Features



- UL Listed 2-gang assembly complete with UL Listed safety-interlocked outlets each containing an integral 30A circuit breaker
- Type 4x enclosure manufactured from 14GA seam-welded stainless steel (powder-coated grey)
- (2) safety-interlocked ESL outlets #1706-56ANP factory wired to power distribution block (PDB)
- UL Listed circuit breaker rated 35kAIC @ 480VAC provides short circuit & overcurrent protection at each outlet
- Each outlet's actuator rod allows user to turn on/off and reset tripped breaker
- PDB accepts incoming cable range of (1) #14AWG - 2/0 per phase line side
- Gasketed bolt-on access cover

Drawing

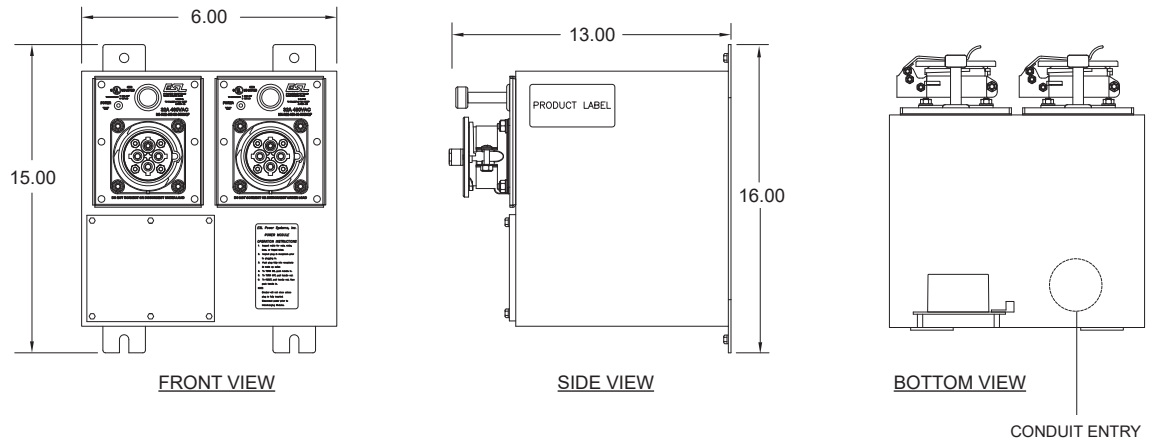

Approvals

- UL/cUL Listed modules and assembly
- UL 489 Listed / CSA certified molded case circuit breakers

Specifications

Catalog No: E2-R32-480-30-35SNQP-SP
 Item No: 2267-59AN

Ratings

2-Gang assembly	60A 480VAC (380 - 480VAC 50/60hz) 3 phase 3 wire + ground, 35kAIC RMS symmetrical amps
Receptacles	32A 480VAC (380/440VAC 50/60 Hz) per IEC 60309-1 & -2
Circuit breakers	30A trip, 35,000AIC @ 480VAC, other trip and AIC ratings available - contact factory
Environmental	Type 4X/IP66
PDB terminals	Line side terminals accept (2) #14 - 2/0 per phase Ground terminal accepts #14 - 2/0

Materials

Stainless steel	Enclosure, access cover, outlet frames, on/off rods, interlock mechanisms, contact terminal screws & springs, snap covers and all fasteners
Aluminum	PDB Lugs
Nickel plated brass	Contact sleeves
Rynite®	Receptacle insert
Polyamide	Receptacle housing
Buna-N (Nitrile/NBR)	O-rings, gaskets, cover seals

Approximate Weight

Approx. weight	31 lbs.
Approx. shipping weight	36 lbs.

Replacement Parts

Description	Item No.	Description	Item No.
Safety-interlocked power outlet	1706-56ANP	Circuit breaker	4020-109
Stainless steel snap cover assembly	1500-01	Ground sleeve kit	4016-03
Replacement receptacle kit	4010-75	Phase sleeve kit	4015-01
Receptacle insert kit	4010-76		