

OutTap® Distribution Unit

UL 891 Listed

2800A, up to 480VAC
Series: 3828

Features



- Solution for temporary remote connection of generator to load bank
- Type 3R heavy gauge galv. steel enclosure with gray powdercoat RAL 7035 (stainless steel & additional colors optional)
- Color-coded cam style female outlets
- Hinged, padlockable access door & dead front panel for safe cam connection and operation
- Hinged access plate secures cable entry compartment when not in use
- Optional dead switch on door for customer's use to activate up stream breaker
- Pad mount

Drawing

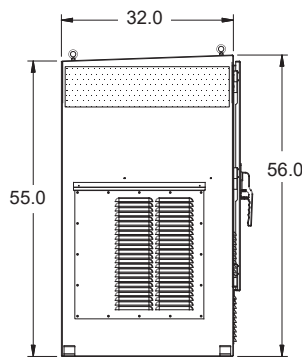

LEFT VIEW

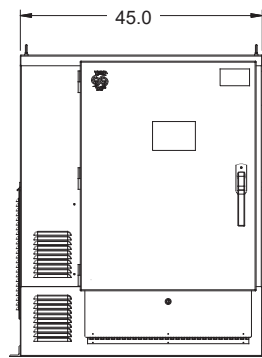

FRONT VIEW

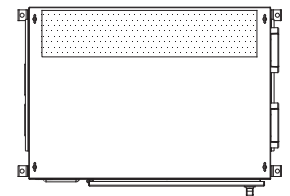

TOP VIEW

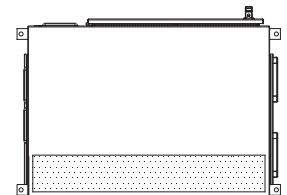

BOTTOM VIEW

Available incoming conduit entry locations shown shaded.

Approvals

- UL/cUL 891 Listed assembly
- UL 1691 Listed receptacles

Specifications

UL 891 Listed

OutTap® Distribution Unit
Series: 3828

Ordering Information

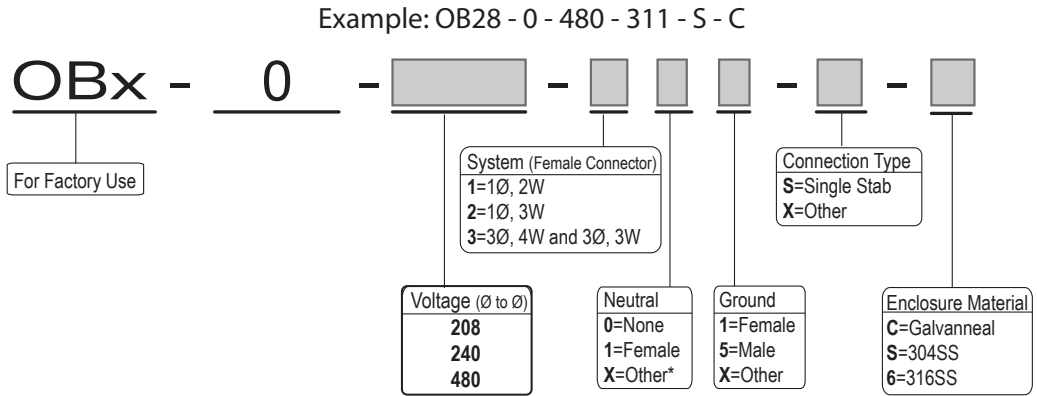

Contact factory for additional options

Ratings

Withstand rating	42kA @ 208VAC to 480VAC
Cam-style receptacles	(7) Sets of 400A, 600VAC for phase & neutral (4) 400A, 600VAC for ground
Environmental	Type 3R, gasketed (Type 3RX with 304SS or 316SS option)
Cable terminations	Mechanical Lugs (8) 300 - 800kcmil per phase and neutral (if applicable) (8) 2AWG - 600kcmil for ground

Packaging

Approximate product weight	720 lbs.
Approximate shipping weight	760 lbs.