

eTRUconnect® V2 PS Series (Daisy-chain Capable) TRU Docking Station

Features

30A 480VAC 3PH 3W + G
Cat: ETRU2-1-PS-30-480-30-35-G-BD-L*
Item No: 6002-001-L*



* Cord length in feet (5 foot increments)
replaces "L" in the catalog number.

- UL Listed 1-gang power station for energizing refrigerated truck/trailers, complete with safety-interlocked door and custom length power cord (5' increments)
- UL Listed 30A 3P circuit breaker rated 35kAIC @ 480VAC provides short circuit & overcurrent protection
- Cord includes female connector with integral sensor to prove loop is complete before cord can be energized; system "trips" if proving loop is broken (unplugged, cut cord, drive-off, etc.)
- Cord has break-away provisions enabling a technician to re-connect cord after unintentional "drive-off" while still plugged in
- Ultra-bright Red LED indicates female connector is energized
- Type 3R enclosure manufactured from 16GA seam-welded steel (powder-coated texture light green)
- Compact footprint for installation in tight spaces between dock doors
- Factory wired complete to power distribution block for customer's 480VAC power connection
- Capable of daisy chaining (max wire size 2AWG)

Drawing

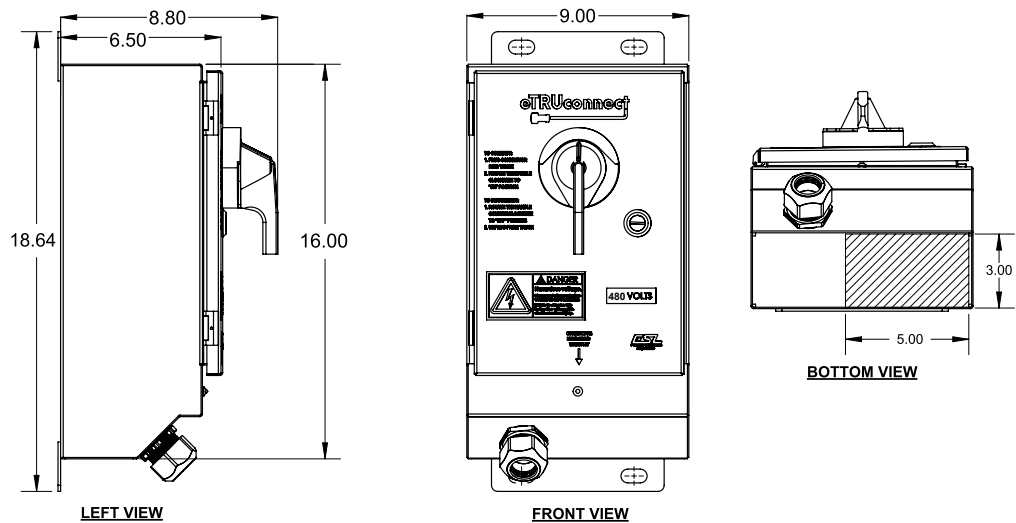

Approvals

- UL Listed

Specifications

Catalog No: ETRU2-1-PS-30-480-30-35-G-BD-L*

Item No: 6002-001-L*

Ratings

Female connector	30A 480VAC, 3 phase, 3 wire + ground (7hr per IEC 60309-1)
Power cord	600V, 10 gauge, 6 conductor SOOW heavy-duty black cord
Circuit breaker	3P molded case 30A trip, 35kAIC @ 480VAC with UVR, other trip and AIC ratings available - contact factory
Environmental	Type 3R
Terminal blocks	Installer wires to power distribution block: (3) phase & (1) ground pressure type screw terminals: #14 - #2 AWG (2.5-35mm ²) wire range

Materials

Steel	Enclosure, access door
Polyamide	Female connector body, lock ring, cover
Phenolic	Female connector contact carrier
Brass	Female connector contact sleeves
Buna-N (Nitrile/NBR)	O-rings, gaskets

Packaging

Approx. weight	25 lbs.
Approx. shipping weight	35 lbs.
Shipping dimensions	15in x 16in x 6.5in

Options

Pole mount hardware kit for 3" or 4" diameter pipe	Pad mount stand
Auxiliary contact	Cord Hanging Post
LED signal light	

Replacement Parts

Description	Item No.	Description	Item No.
Red LED kit	4090-40RH	Operating mechanism	4065-005
Cord w/female connector	4065-001-L*	Handle	4065-006
Breaker w/ UV	4065-003	Transformer	4065-007
Shaft	4065-004		

*Cord length in feet (5 foot increments) replaces "L" in the item number.