

ESL
POWER SYSTEMS
AN EMPLOYEE OWNED COMPANY

EMERGENCY POWER

EMERGENCY POWER CONNECTION EQUIPMENT



NEC 700.3 (F) Compliant • UL 1008 LISTED

STORMSWITCH® | TRIPLESWITCH® | TEMPTAP™ | OUTTAP™

DUALCONNECT™ | READYCONNECT™ | ROTARYCONNECT™

Importance of Emergency Power

The reliability of power over the past 15 years has been strained by increased demand of growing populations, aging infrastructure and more frequent occurrences of extreme weather. There is often a large cost impact for businesses without backup power during power outages. These costs include lost output and wages, spoiled inventory, inconvenience and the cost of restarting industrial operations.

The graphs below illustrate an unmistakable rise in the number of power grid outages as well as weather related downtime.

2006-2021 Billion Dollar Disaster Cost¹

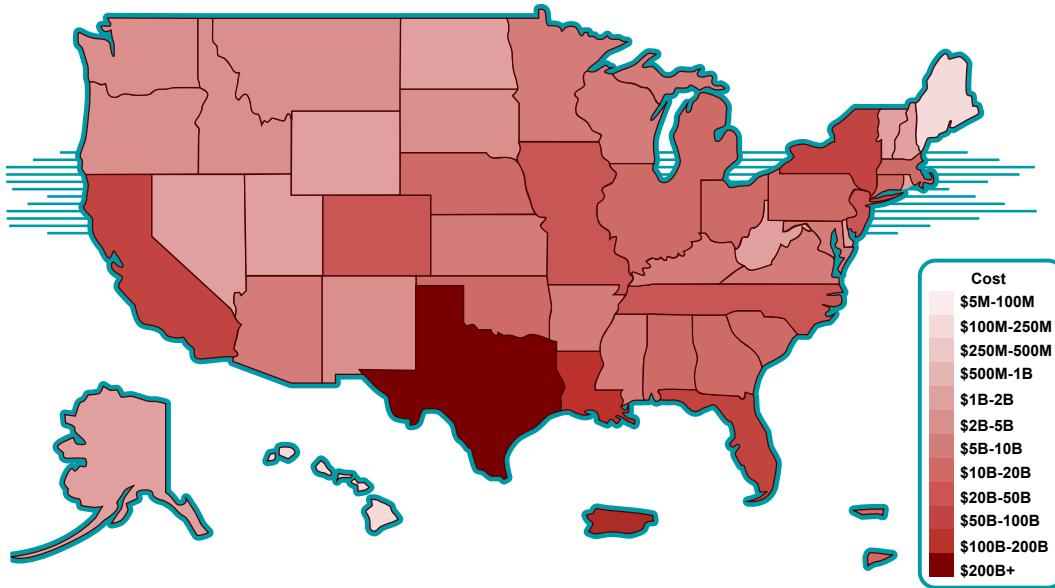

The costs associated with unscheduled power outages (i.e. weather related) are influenced by the amount of time that the power is out.

Interruptions in electricity service to customers vary in frequency and duration across the nearly 3,000 electric distribution systems that serve about 155 million customers in the United States.

2017 represented a year with more hurricanes, wildfires, and severe storms totaling nearly 8 hours without power for utility customers. In 2019, U.S. customers experienced an average of 3.2 hours of interruptions during major events and 1.5 hours of interruptions without major events, or nearly 5 hours total.

As the climate changes and infrastructure ages, the economic and social impacts of power outages may be unavoidable. However, the effects can be mitigated by being diligent and taking appropriate steps to minimize operational downtime. ESL's emergency power connection equipment is very cost-effective, especially when compared to the cost of being without power for extended periods of time. In addition, our emergency power products provide users with safe and simple operation so that grid-tied facilities can quickly connect to portable power when it matters most.

Average duration of total annual interruption in electricity service²

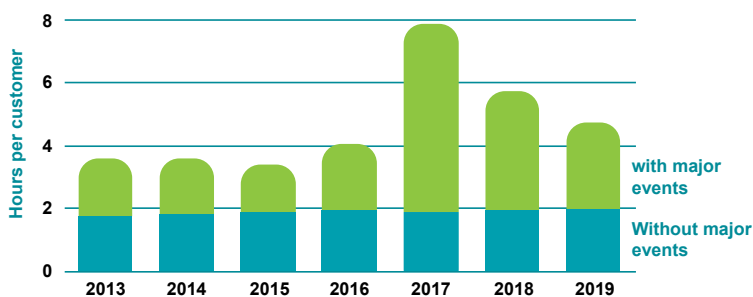

Average length of outages per year³

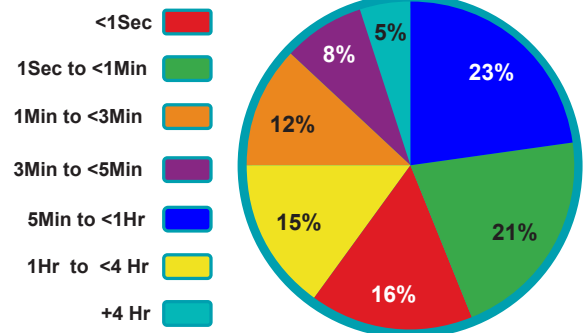

(1) NOAA National Centers for Environmental Information (NCEI) U.S. Billion-Dollar Weather and Climate Disasters (2022) | <https://www.ncdc.noaa.gov/billions>

(2) US Energy Information Administration | <https://www.eia.gov>

(3) The Cost of Power Disturbances to Industrial and Digital Economy Companies | [epri.com](https://www.epri.com)

Index

StormSwitch® Manual Transfer Switch	1
Manual transfer switches provide an economical and safe solution for grid-tied facilities to quickly and easily connect a portable generator when utility power is out.	
StormSwitch® BeBe (225-400A Compact)	2
StormSwitch® Pad-mounted	3
TripleSwitch® 3-way Manual Transfer Switch	5
ESL's 3-way manual transfer switch system is designed to service facilities that utilize an automatic transfer switch and a permanent generator. The TripleSwitch provides ease of connection for load bank testing and portable generator backup.	
TripleSwitch® Pad-mounted	7
TempTap™ Generator Docking Station	9
Provides a simple connection point for a portable generator hook-up to a building's power system.	
OutTap™ Outlet Box without Circuit Breaker	13
OutTap™ Outlet Box with Circuit Breaker	14
ReadyConnect™ Automatic Transfer Switch (ATS) with Cams	15
ReadyConnect provides the ability to proactively connect back-up power before planned outages.	
DualConnect™ Dual Purpose Docking Station	17
Designed for emergency backup systems with either multiple or existing generators.	
DirecTap™ Termination Cabinet	19
Frequently Asked Questions	20

StormSwitch®

**UL/cUL
1008
LISTED**

Manual Transfer Switch

UL 1008 Listed 70A – 800A • Wall Mount

ESL's UL/cUL 1008 Listed StormSwitch manual transfer switch is the ideal solution for portable generator connection to grid-tied facilities. StormSwitch combines a robust commercial-grade transfer switch with color-coded cam-style connectors for quick connection to a portable power generator.

Integral utility and generator manual disconnects are interlocked to prevent cross connecting the power sources. Once installed by a licensed electrician, the StormSwitch is so easy and safe to operate that only basic training is required.

Buying and installing automatic transfer switches with a permanent generator for each site can be quite costly and requires ongoing maintenance. With StormSwitch, multiple locations can be equipped with a manual transfer switch and share a single portable generator, a significant cost savings.



800A StormSwitch

StormSwitch Applications

- Gas Stations/ Convenience Stores
- Water Wastewater
- Call Centers
- Manufacturing
- Financial Centers
- Cold Storage Facilities
- Grocery Stores
- Distribution Centers
- Restaurants
- Petrochemical
- Health Care Facilities

StormSwitch Features

- Interlocking mechanism prevents cross-connecting power sources
- Safety-interlocked door and dead front panel
- Utility and generator 3-pole disconnects
- 400A rated color-coded cam-style connectors (male) for easy connections
- Type 3R double coated, cold-rolled steel enclosure (stainless steel, Type 3RX, & colors optional)
- Hinged, padlockable access door with door stoop
- Hinged plate secures cord entries when not in use
- Suitable for use as service equipment in USA
- UL /cUL 1008 Listed up to 3000A
- Aux contacts (to comply with NEC 700.3(F))
- Terminal strip (for devices like remote generator start, remote monitoring)
- Phase monitor
- OSHPD Seismic Certification (OSP)*
*excludes 225A - 400A StormSwitch BeBe™

StormSwitch Optional Features

- Utility ON indicator (unit mounted or remote mounted)
- 4-pole disconnects (switched neutral)
- 20A & 30A 125VAC or 240VAC receptacles (battery chargers, heaters)
- SCADA (Supervisory Control and Data Acquisition to connect to a PLC)
- Leg kits
- Posi-Lok™ cams[†]*

[†]Posi-Lok™ is a Trademark of Crouse-Hinds
* Consult Factory

StormSwitch Connection to Portable Generator

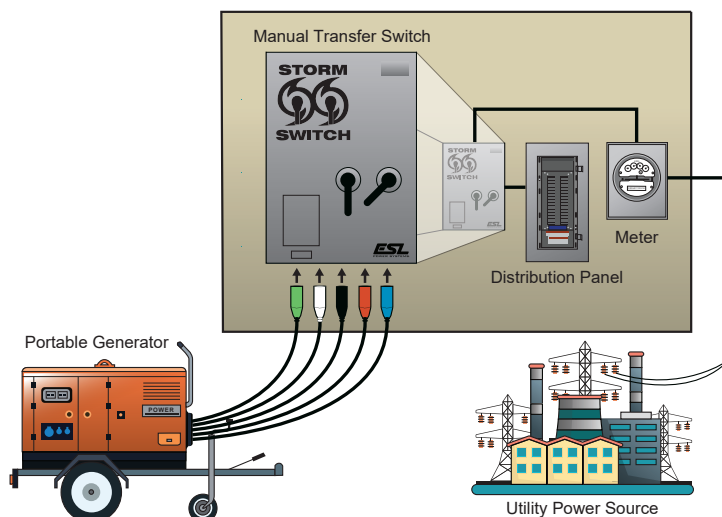

Dim	3020	3040	3060	3080
A	30"	45"	53"	55"
B	24"	34"	42.5"	46"
C	13.4"	14.6"	15.5"	16.6"
D	10.4"	11.4"	12.3"	13.4"
Approx Lbs.	138	310	450	680

Note: Dimensions and weights are subject to change.

- Suitable for use as Service Equipment (SUSE) in USA
- Type 3R enclosure
- UL /cUL 1008 Listed Assembly
- U.S. Pat. #7462792

StormSwitch® BeBe

Compact Manual Transfer Switch

UL 1008 Listed 225A – 400A • Wall Mount

**UL/cUL
1008
LISTED**



The StormSwitch BeBe is UL/cUL 1008 Listed and provides the same ideal solution for portable generator connection to grid-tied facilities but with a 33% smaller footprint than the original 400A StormSwitch.

This compact manual transfer switch weighs less than ESL's standard StormSwitch and makes for an easy installation. The StormSwitch BeBe (Bottom Entry Bottom Exit) accepts conduit entries through the bottom left side of the enclosure.

Like all of ESL's emergency power products, the StormSwitch BeBe provides operators with color-coded cam-style receptacles to ensure a quick, safe connection to a portable generator, and is a cost effective UL1008 Listed solution to the traditional double throw switch.

400A StormSwitch BeBe

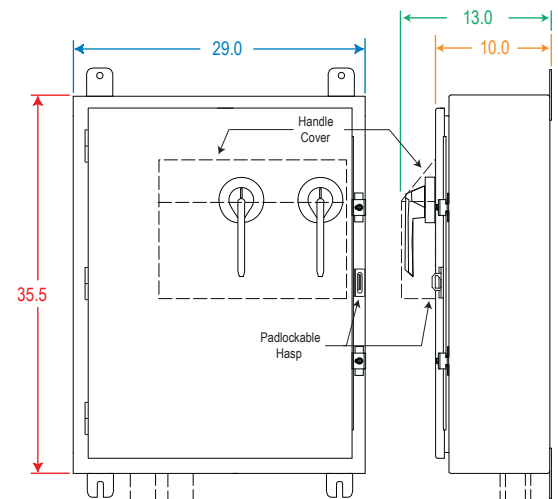

(Bottom Feed Only)

Typical Configurations • 225A - 400A • Up to 600VAC

Model	Current Rating (Amps)	Line Terminals (Wire Range)	Neutral / Load Terminals (Wire Range)	Ground Lug (Wire Range)	Cam-style Receptacle Size (Amps)
3042 Series†	225-400	(2) 2/0 - 500	(2) #2 - 500	#6 - 250	400

Note: Other options available - consult the factory.

†3042 Series with circuit breaker are furnished with adjustable electronic trips.

Approximate weight: 160 lbs

Product Selection Information: For StormSwitch BeBe

Example: SFD4 - 400C - 400C - 480 - 311- S - C

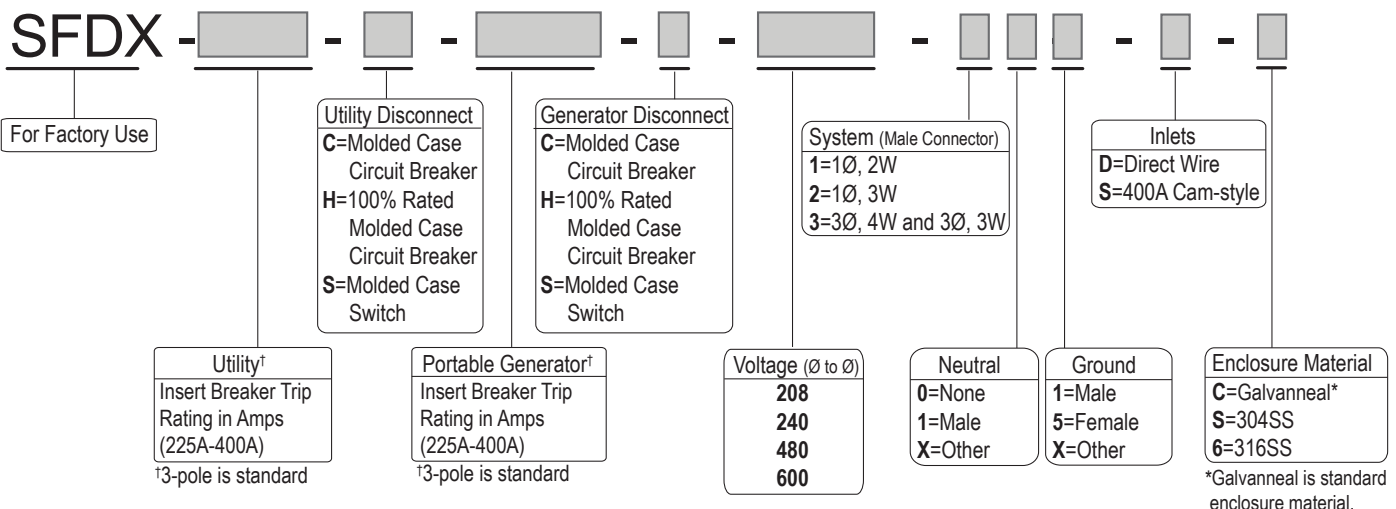

StormSwitch®

Manual Transfer Switch

UL 1008 Listed 1000A – 3000A • Pad Mount

Available up to 5000A

ESL's UL/cUL 1008 Listed pad-mounted StormSwitches range from 1000A - 3000A and include a main padlockable door with separate lower hinged panel for emergency generator cable access.

These higher amperage units include a fixed deadfront over 3-pole circuit breakers, hinged deadfront for emergency power cable hook-up, ventilation louvers, and removable lifting pads. Left side wire way is standard for bottom feed up to 3000A. Dual side wireway available for all units.

Applications

- Banks/Financial Centers
- Grocery Stores
- Gas Stations
- Data Centers
- Cell Sites
- Retail Stores
- Schools
- Healthcare Centers
- Law Enforcement Facilities
- Water/Wastewater Facilities
- Evacuation Centers



**UL/cUL
1008
LISTED**

3000A StormSwitch

StormSwitch Pad Mount Features

- Interlocking mechanism prevents cross-connecting power sources
- Door & dead front panel for safe generator connection and operation
- Utility and generator 3-pole disconnects
- 400A rated color-coded cam-style connectors (male) for easy connections
- Type 3R double coated, cold-rolled steel enclosure (stainless steel, Type 3RX, & colors optional)
- Hinged plate secures cord entries when not in use
- Suitable for use as service equipment in USA
- UL /cUL 1008 Listed up to 3000A
- Aux contacts
- NEC 700.3(F)
- Terminal strip (for devices like remote generator start, remote monitoring)
- Phase monitor
- OSHPD Seismic Certification (OSP)

StormSwitch Pad Mount Optional Features

- Suitable for Use as Service Equipment (SUSE) in USA
- Utility ON indicator (unit mounted or remote mounted)
- 4-pole disconnects (switched neutral)
- 20A & 30A 125VAC or 240VAC receptacles (for battery chargers, heaters)
- SCADA (Supervisory Control and Data Acquisition) to connect to a PLC)
- Posi-Lok cams †*

†Posi-Lok™ is a Trademark of Crouse-Hinds
* Consult Factory

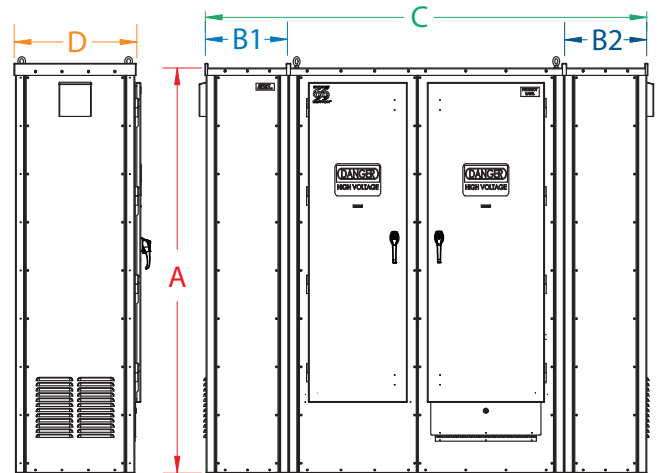
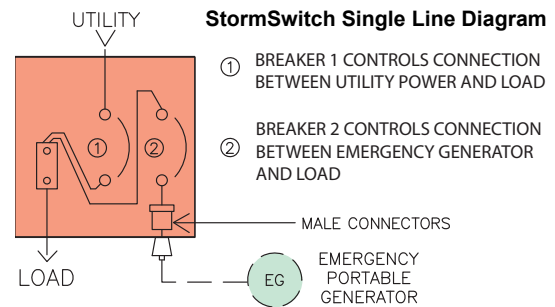

Dim	3012	3016	3022	3024	3028	3032
A	88"	88"	88"	88"	88"	88"
B1	14"	14"	14"	18"	18"	18"
B2	-	-	-	18"	18"	18"
C	62"	62"	62"	96"	96"	96"
D	24"	24"	24"	27"	27"	27"
Approx Lbs.	1600	1600	1600	1800	1800	1800

Note: Dimensions and weights are subject to change. Please verify with factory.
• Type 3R enclosure • UL /cUL 1008 Listed Assembly

Product Selection Information:

70A – 3000A

Example: SSD8 - 800C - 800C - 480 - 311 - S - C

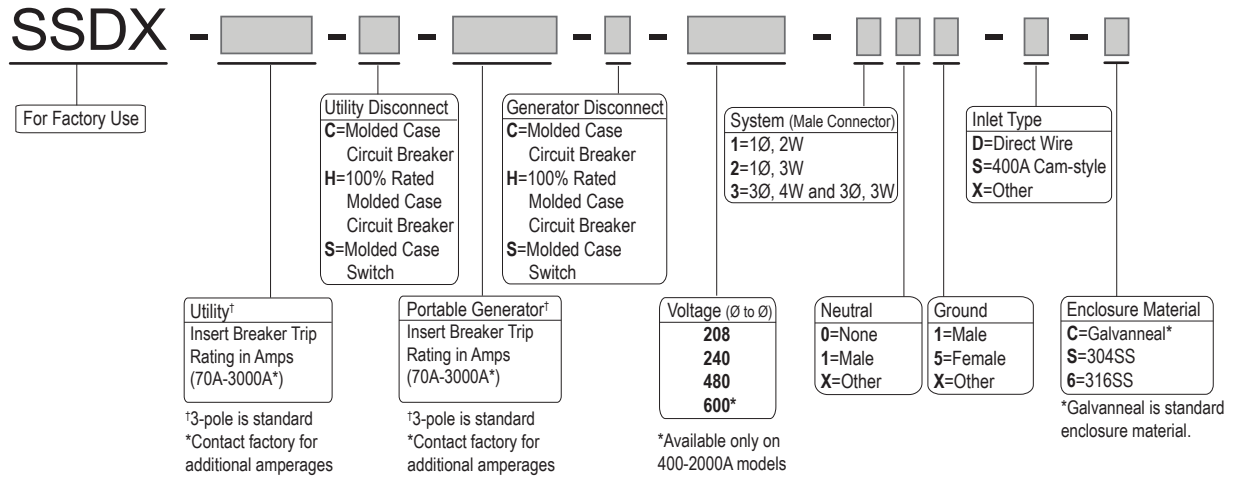

800A units or below are SUSE rated as standard. SUSE rated is optional on larger units

Typical 3-pole Configurations • 70A - 3000A • Up to 480VAC or 600VAC

Model	Current Rating (Amps)	Line Terminals (Wire Range)	Neutral / Load Terminals (Wire Range)	Ground Lug (Wire Range)	Cam-style Receptacle Size (Amps)
3020 Series	70, 100, 125, 150	(1) #14 - 3/0	(2) #6 - 4/0	(2) #6 - 250	400
	175	(1) #4 - 4/0	(2) #6 - 4/0	(2) #6 - 250	400
	200	(1) 3/0 - 350	(2) #6 - 4/0	(2) #6 - 250	400
3040 Series†	400 max	(1) #2 - 600	(4) #2 - 600	(2) #6 - 300	400
3060 Series	300, 350, 400, 450, 500, 600	(3) 3/0 - 500	(4) #2 - 600	(2) #6 - 300	(2) 400
3080 Series	300, 350, 400, 450, 500, 600, 700, 800	(3) 3/0 - 500	(4) 1/0 - 750	(2) #6 - 300	(2) 400
3012 Series	1200 max	(4) 3/0 - 500	(4) 1/0 - 750	(4) 1/0 - 750 (1) #2 - 600	(3) 400
3024 Series	2400 max	(8) 300 - 800	(8) 300 - 800	(9) #2 - 600	(6) 400
3028 Series	2800 max	(8) 300 - 800	(8) 300 - 800	(9) #2 - 600	(7) 400
3032 Series	3000 max	(8) 300 - 800	(8) 300 - 800	(9) #2 - 600	8) 400

Note: other options such as 4-pole (switched neutral) available - consult the factory.

†3040 Series with circuit breaker are furnished with adjustable electronic trips.



TripleSwitch®

3-way Manual Transfer Switch

UL 1008 Listed 125A - 3000A

Available up to 5000A

Load bank testing can be challenging and time consuming. ESL's UL/cUL 1008 Listed TripleSwitch is a dual purpose solution to service those facilities that utilize an automatic transfer switch and a permanent generator.

The TripleSwitch includes three breakers which allow the permanent generator to be simultaneously connected to both a load bank and the ATS. Two mechanically interlocked breakers prevent cross connecting the permanent standby generator and the portable generator.

ESL's TripleSwitch combines female quick connect cams for the load bank, and male quick connect cams for a portable backup generator. Connections are simple and quick, reducing set-up times and wiring mistakes.



800A TripleSwitch

Cost Advantages of the TripleSwitch:

- Man power to run testing process is reduced
- Reduction of testing set-up and disconnect time
- Prevents costly repairs of stripped lugs on permanent generator
- Provides a redundant and safe way to connect a backup generator in the event the permanent generator malfunctions, requires maintenance or repairs, or if utility power to your facility fails during load bank testing

TripleSwitch Features

- Interlocking mechanism prevents cross- connecting power sources
- Safety-interlocked door & dead front panel
- Load bank and portable generator disconnects
- 400A rated color-coded cam-style receptacles for easy back-up generator (male) & load bank connection (female)
- Type 3R double coated, cold-rolled steel enclosure (stainless steel, Type 3RX, & colors optional)
- Hinged, padlockable access doors with door stops
- Hinged lower plate secures cord entries when not in use
- 3-pole circuit breakers std. (4-pole circuit breakers optional)
- Phase monitor
- Terminal strip (for devices like remote generator start, remote monitoring)
- UL /cUL 1008 Listed up to 3000A
- OSHPD Seismic Certification (OSP)



3000A TripleSwitch Padmount

TripleSwitch Optional Features

- Utility ON indicator (unit mounted or remote mounted)
- 20A & 30A 125VAC or 240VAC receptacles (for battery chargers, heaters)
- SCADA (Supervisory Control and Data Acquisition to connect to a PLC)
- Leg kits for wall mount units
- Extended enclosures for bottom-fed wall mount units

Applications

- Healthcare Facilities
- Data Centers
- Banks/Financial Centers
- Emergency Operations Centers
- Tunnels & Bridges
- Cable TV Distribution Centers

TripleSwitch®

3-way Manual Transfer Switch

125A - 3000A

Diagrams below represent TripleSwitch operating functions during various conditions

Normal Operation

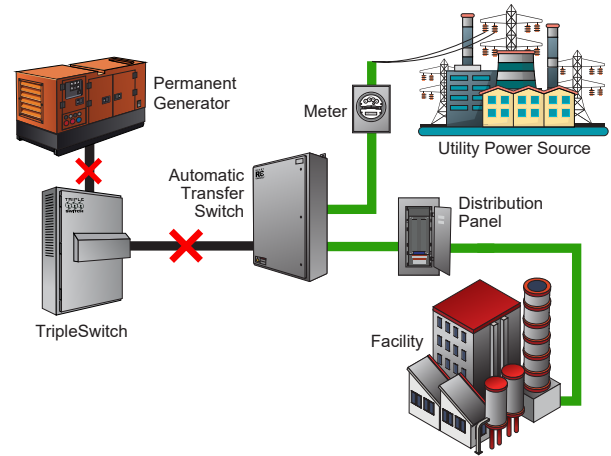

Permanent Generator Running During Utility Power Outage

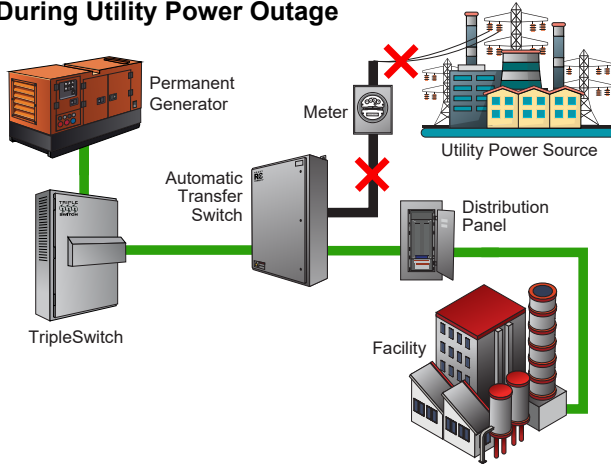

Load Bank Testing Under Normal Power Situation

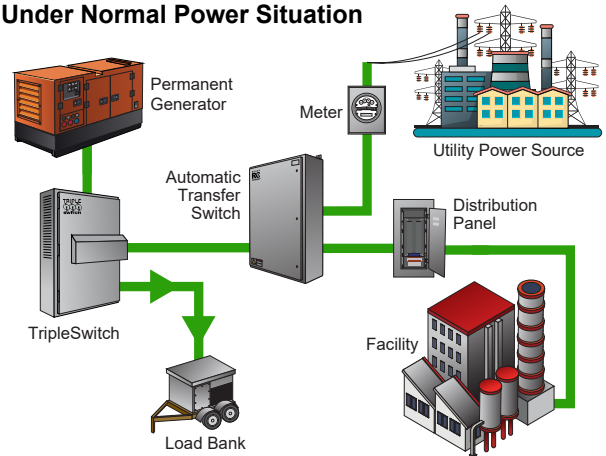

Load Bank Testing Shunt Trip Activated During Utility Power Outage

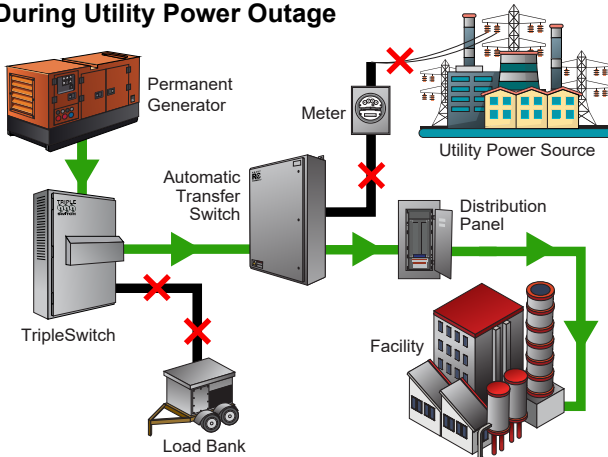

Portable Emergency Generator Connected and Running Permanent Generator Out of Service During Power Outage

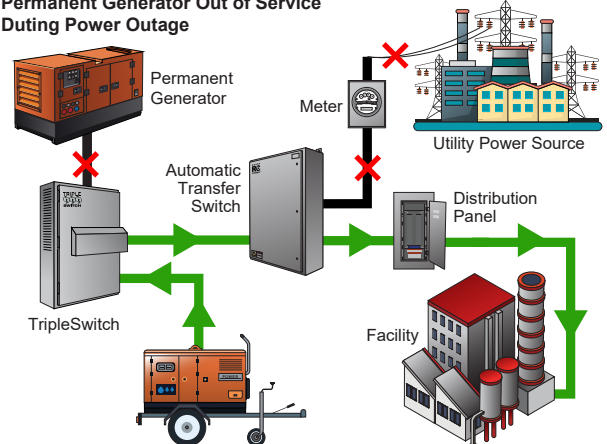

TripleSwitch®

1000A - 3000A • Pad Mount

**UL/cUL
1008
LISTED**

ESL's UL/cUL 1008 Listed pad-mounted TripleSwitches range from 1000A - 3000A up to 480VAC and include two main padlockable doors with separate lower hinged cable-pass-through panels for load bank testing and emergency generator connections.

The interior of these higher amperage units include fixed deadfronts over 3-pole circuit breakers and termination lugs; below the breakers are hinged deadfronts for emergency power cable hook-up. Left side wireway is standard for bottom utility feed up to 1600A. Dual side wireway is available from 2000A - 3000A.



1200A TripleSwitch

TripleSwitch Single Line Diagram

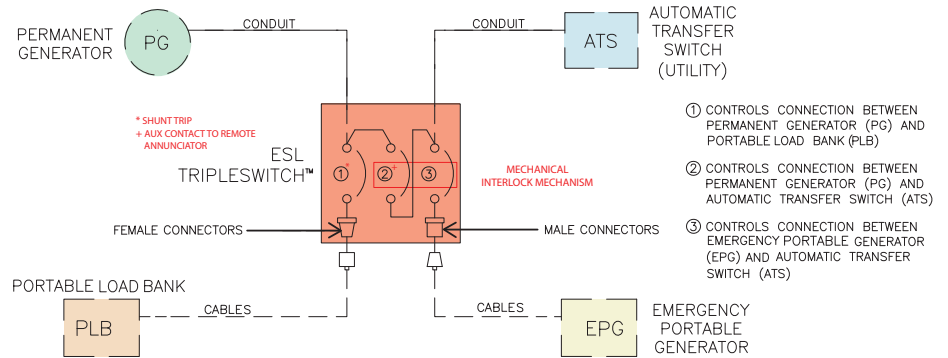

Typical Configurations • 1000A - 3000A • Pad Mount • Up to 480VAC

Model	Max Current Rating (Amps)	Line / Load Terminals (Wire Range)	Ground Lug (Wire Range)	Cam-style Receptacle Size (Amps)
3112 Series	1200 max	(4) #2 - 600	(9) #6 - 350	(3) 400A Male, (3) 400A Female
3116 Series	1600 max	(4) 1/0 - 750	(9) #2 - 600	(4) 400A Male, (4) 400A Female
3122 Series	2000 max	(6) 300 - 800	(9) #2 - 600	(5) 400A Male, (5) 400A Female
3124 Series	2400 max	(8) 300 - 800	(9) #2 - 600	(6) 400A Male, (6) 400A Female
3128 Series	2800 max	(8) 300 - 800	(9) #2 - 600	(7) 400A Male, (7) 400A Female
3132 Series	3000 max	(8) 300 - 800	(9) #2 - 600	(8) 400A Male, (8) 400A Female

Other options such as 4-pole (switched neutral) available - consult the factory.

Dim	3112	3116	3122	3124	3128	3132
A	89	89	89	89	89	89
B1	28	28	18	18	18	18
B2	-	-	18	18	18	18
C	104	104	104	112	112	112
D	76	76	76	76	76	76
E	24	24	26.5	26.5	26.5	26.5
Approx. lbs.	3300	3300	3300	3400	3400	3400

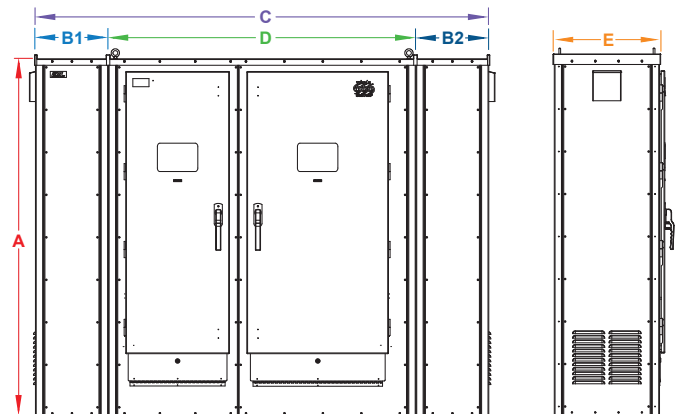

Note: Dimensions and weights are subject to change. Please verify with factory.

Product Selection Information:

125A – 3000A

Example: M3D8 - 800C - 800C - 800C - 480 - 311 - S - C

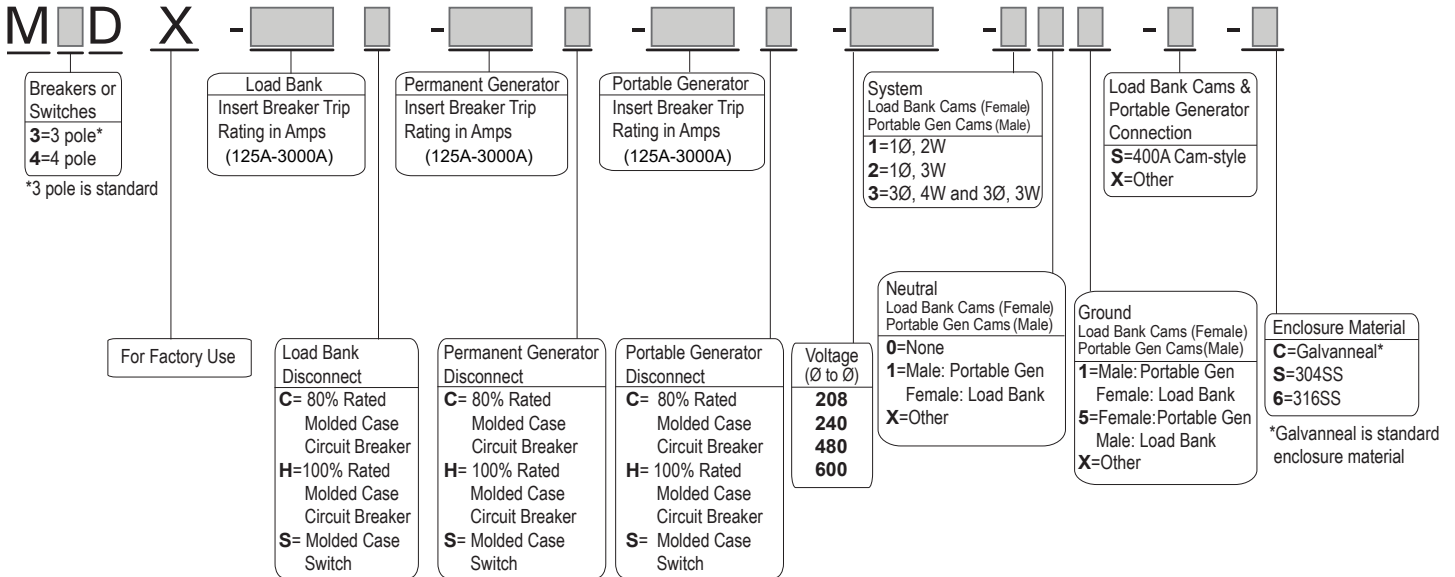

Typical Configurations • 125A - 800A • Wall Mount • Up to 600VAC

Model	Current Rating (Amps)	Line / Load Terminals (Wire Range)	Ground Lug (Wire Range)	Cam-style Receptacle Size (Amps)
3141 Series	125 - 400	(2) 2/0 - 500	(2) #6 - 300	400
3181 Series	300, 350, 400, 450, 500, 600, 700, 800	(3) 3/0 - 500	(2) #6 - 300	(2) 400

Other options available - consult the factory.

Note: If neutral switching is required, please contact ESL for details.



Dim	3141	3181
A	46.5"	55"
B	34"	46"
C	14.6"	16.5"
D	11.5"	13.3"
Approx. lbs.	370	540

Note: Dimensions and weights are subject to change. Please verify with factory.

- Type 3R enclosure
- UL/cUL 1008 Listed Assembly

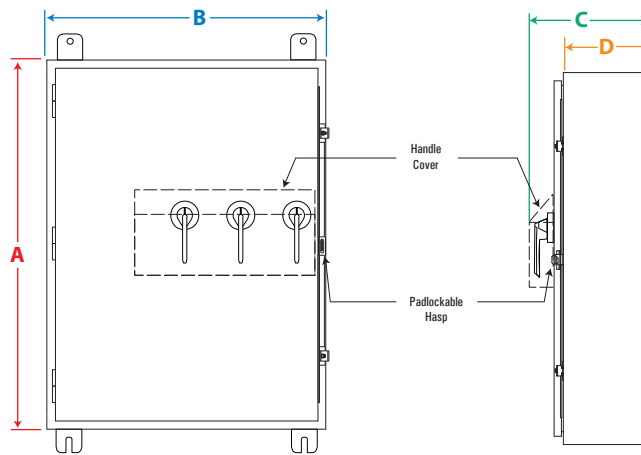

TempTap™

Generator Tap Box (Inlet box)

400A - 1600A • Wall Mount

Also available with breaker

UL/cUL
1008
LISTED

ESL's UL/cUL 1008 Listed TempTap generator docking stations are designed to provide end users with a safe and simple solution to connect a portable generator to a grid-tied facility.

TempTap is a pass-through junction box that can be mounted to a building and is typically hard-wired to an upstream circuit breaker enclosure or system, such as a transfer switch or utility disconnect. Similar to ESL's StormSwitch, TempTap provides operators with color-coded cam-style receptacles to ensure a quick, safe connection to a portable generator.



TempTap Connection to Portable Generator (with StormSwitch indoors)

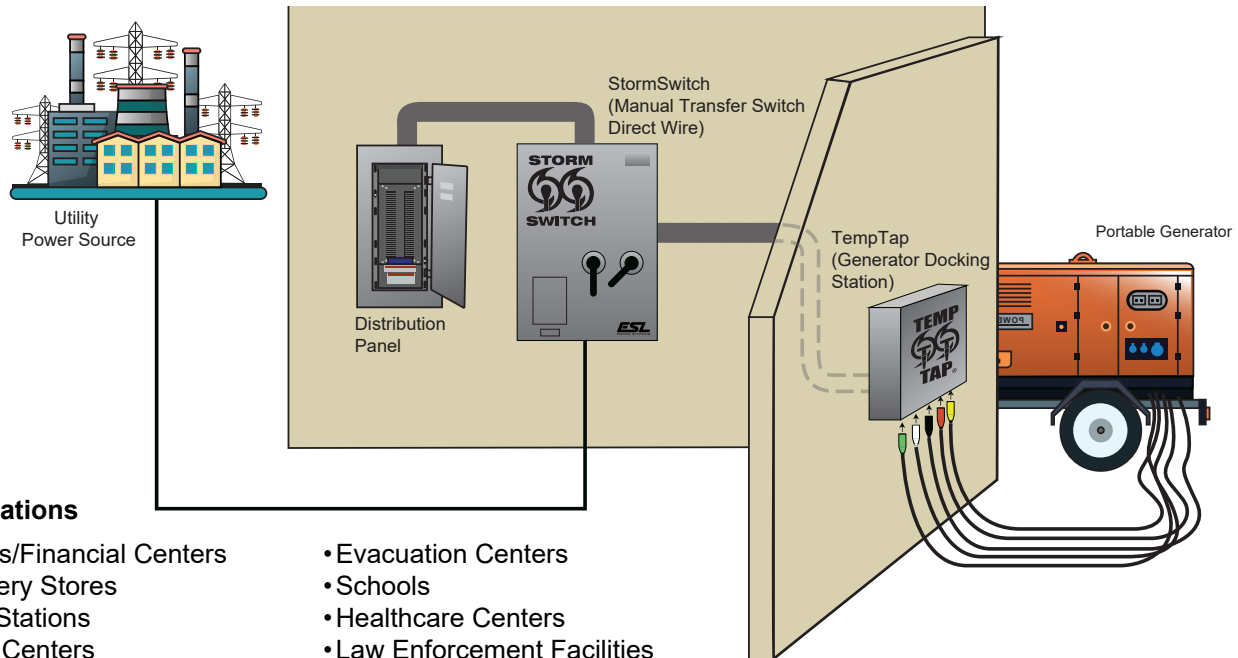

Applications

- Banks/Financial Centers
- Grocery Stores
- Gas Stations
- Data Centers
- Cell Sites
- Retail Stores
- Water/Wastewater Facilities
- Evacuation Centers
- Schools
- Healthcare Centers
- Law Enforcement Facilities
- Load Bank Testing
- Toll Booths

TempTap Features

- 400A rated color-coded cam-style connectors (male) for easy connection
- Terminal strip (for devices like remote generator start, remote monitoring)
- Type 3R double coated, cold-rolled steel enclosure (stainless steel, Type 3RX, & colors optional)
- Hinged, padlockable access door with door stop
- Hinged plate secures cord entries when not in use
- Use in conjunction with a manual/automatic transfer switch
- UL/cUL 1008 Listed up to 3200A

TempTap Optional Features

- Phase monitor
- Utility ON indicator (unit mounted bottom feed optional or remote mounted)
- 20A & 30A 125VAC or 240VAC receptacles (for battery chargers, heaters)
- SCADA (Supervisory Control and Data Acquisition) to connect to a PLC
- Leg kits
- Posi-Lok cams †*
- Extended depth enclosures for bottom-fed units

†Posi-Lok™ is a Trademark of Crouse-Hinds
* Consult Factory

Product Selection Information: 400A – 1600A • Wall Mount

**UL/cUL
1008
LISTED**



1600A TempTap

Example: IB8 - 480 - 311 - S - C

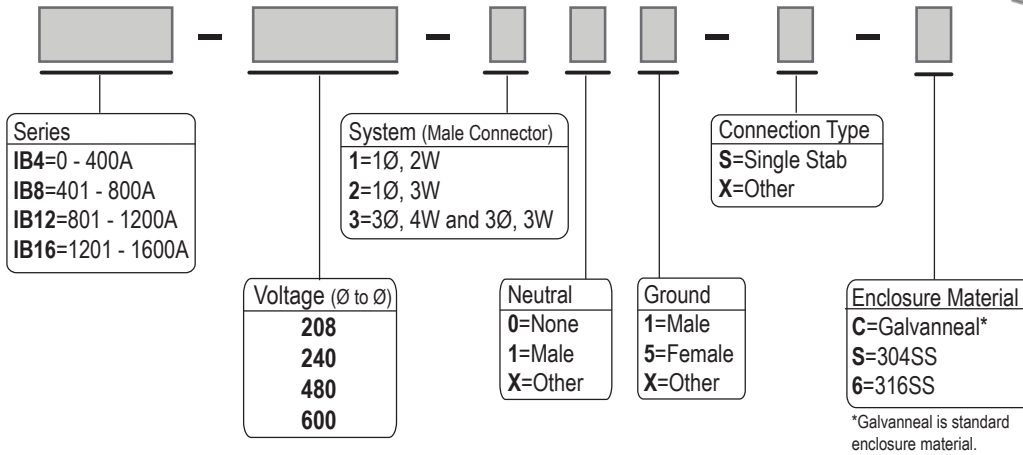

Typical Configurations • 400A - 1600A • Wall Mount • Up to 600VAC

Max Current Rating (Amps)	Model	Load Terminals Per Phase & Neutral	Ground Lug (Wire Range)	Cam-style Receptacle Size Per Phase & Neutral (Amps)	Ground Cam-style Receptacle Size (Amps)	Max Current Withstand Rating (KA)
400	IB4	(1) 1/2 - 13x7/8" stud	(1) #6-250	(1) 400	(1) 400	22 (Single PH) 42 (3 PH)
800	IB8	Copper pad with (6) 0.53" holes on 1 3/4" V x 1" H	(1) #6-250	(2) 400	(1) 400	42
1200	IB12	Copper pad with (4) 0.53" holes on 1 3/4" V x 2" H; (2) 0.44" holes on 1 3/8" V	(1) #6-250	(3) 400	(1) 400	42
1600	IB16	Copper pad with (4) 0.53" holes on 1 3/4" V x 2" H; (2) 0.44" holes on 1 3/8" V	(1) #6-250	(4) 400	(1) 400	42

Other options available - consult the factory.

Dim	IB4	IB8	IB12/ IB16
A	24"	32"	38"
B	17.6"	34"	39"
C	13.3"	15"	16.4"
Approx. lbs.	60	195	260

Note: Dimensions and weights are subject to change. Please verify with factory.

- Type 3R enclosure
- UL /cUL 1008 Listed Assembly

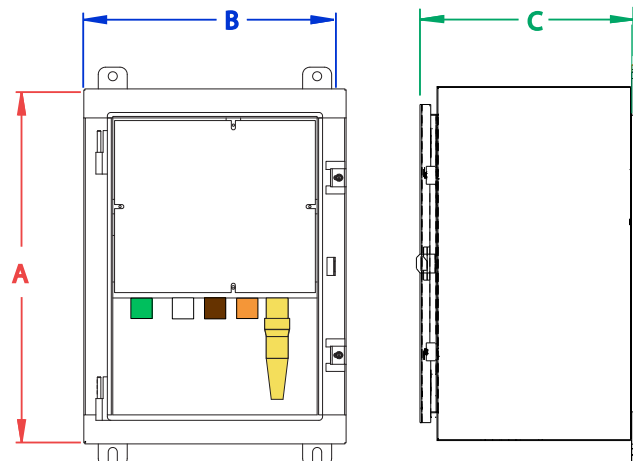

(Shown with door removed)

TempTap™

UL/cUL
1008
LISTED

Generator Tap Box (Inlet box)

UL 1008 Listed 2000A - 3200A • Pad Mount

Available up to 5000A

ESL's UL/cUL 1008 Listed pad mounted generator docking stations range from 2000A to 3200A and provide a quick connection point for a portable backup generator. ESL's pad mounted TempTap has two major uses:

- To be used with a portable generator as the primary emergency generator quick connection point outside a facility (in conjunction with StormSwitch)
- As a quick exterior connection point for a portable generator to back up the permanent standby generator at a critical facility (in conjunction with TripleSwitch)

Designed with multiple conduit entry locations (including bottom feed), the pad mounted TempTap provides a cost effective, easy install and convenient hook up for large trailer mounted portable generators.



3200A TempTap
Also available with breaker

TempTap Generator Connection Box

TempTap and OutTap on exterior of facility, and TripleSwitch on interior

Applications

- Banks/Financial Centers
- Grocery Stores
- Gas Stations
- Data Centers
- Cell Sites
- Retail Stores
- Water/Wastewater Facilities
- Evacuation Centers
- Schools
- Healthcare Centers
- Law Enforcement Facilities
- Load Bank Testing
- Toll Booths

TempTap Features

- 400A rated color-coded cam-style connectors (male) for easy connection
- Type double coated, cold-rolled steel enclosure (stainless steel, type 3RX & colors optional)
- Hinged, padlockable access door with door stop
- Hinged plate secures cord entries when not in use
- Terminal strip (for devices like remote generator start, remote monitoring)
- Use in conjunction with a manual/automatic transfer switch
- UL/cUL 1008 Listed up to 3200A

TempTap Optional Features

- Phase monitor
- Utility ON indicator (unit mounted bottom feed optional or remote mounted)
- 20A & 30A 125VAC or 240VAC receptacles (For battery chargers, heaters)
- SCADA (Supervisory Control and Data Acquisition to connect to a PLC)
- Posi-Lok cams †*

†Posi-Lok™ is a Trademark of Crouse-Hinds
* Consult Factory

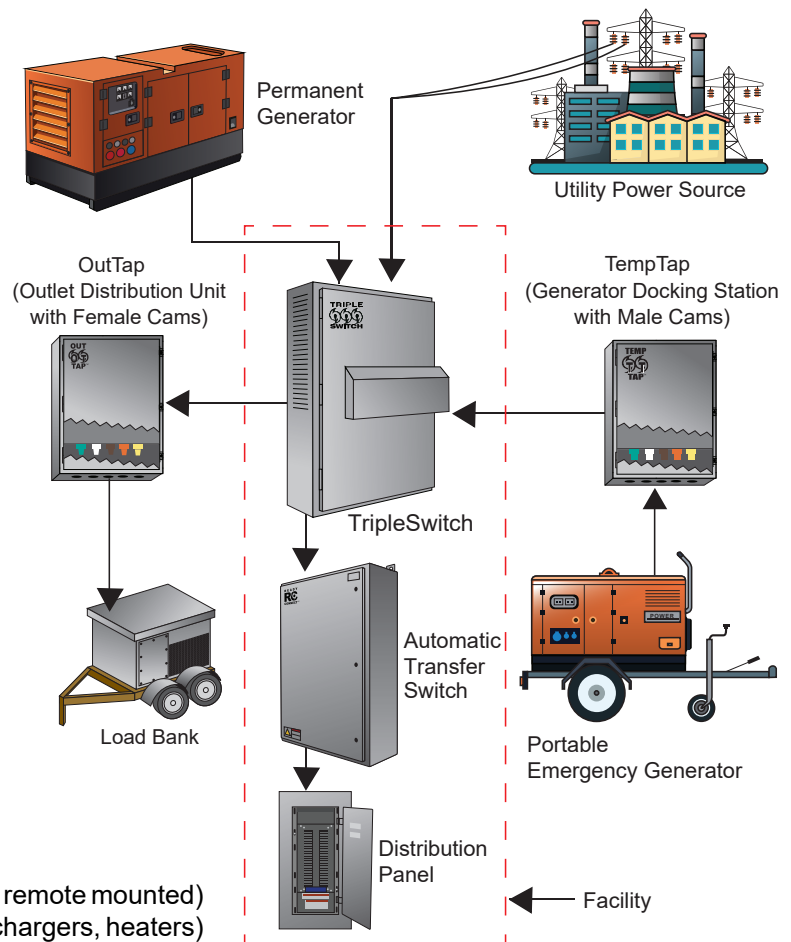

TempTap™

Product Selection Information: 2000A – 3200A • Pad Mount

Example: IB24-480-311-S-C

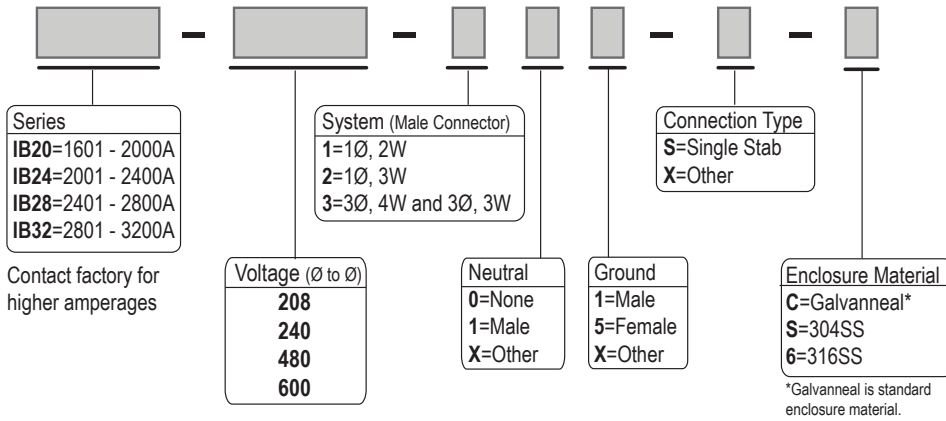

Contact factory for higher amperages

TempTap Single Line Diagram

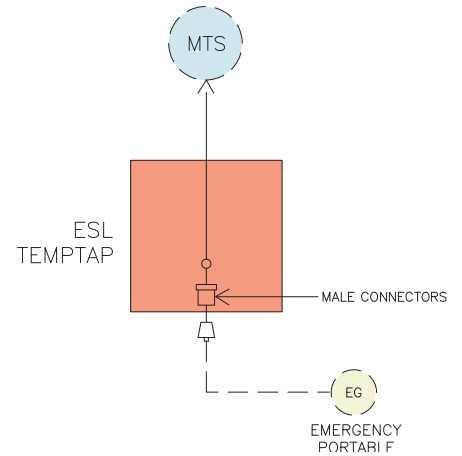

Typical Configurations • 2000A - 3200A • Pad Mount • Up to 480VAC

Max Current Rating (Amps)	Model	Load Terminals Per Phase & Neutral	Ground Lug (Wire Range)	Cam-style Receptacle Size Per Phase & Neutral (Amps)	Ground Cam-style Receptacle Size (Amps)	Max Current Withstand Rating (KA)
2000	IB20	Mech lugs accept (8) 300 - 800 kcmil	(6) #2AWG - 600 kcmil	(5) 400	(3) 400	42
2400	IB24	Mech lugs accept (8) 300 - 800 kcmil	(6) #2AWG - 600 kcmil	(6) 400	(3) 400	42
2800	IB28	Mech lugs accept (8) 300 - 800 kcmil	(6) #2AWG - 600 kcmil	(7) 400	(3) 400	42
3200	IB32	Mech lugs accept (8) 300 - 800 kcmil	(6) #2AWG - 600 kcmil	(8) 400	(3) 400	42

Other options available - consult the factory.
Approximate weight: 725lbs

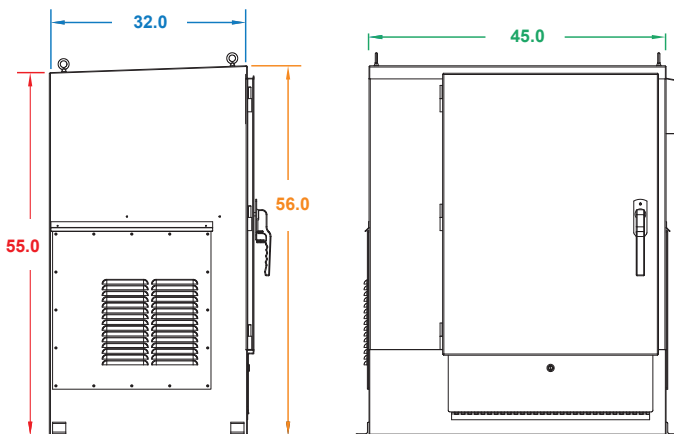

Outlet Box without Circuit Breaker

UL 1008 Listed 400A - 3200A

Available up to 5000A

ESL's OutTap is an UL/cUL 891 Listed outlet box designed to provide end users a safe and simple temporary method of using a facility's electrical power source and distributing it to exterior electrical equipment via quick connect 400A cam-lock cables. This solution is often used in lieu of utilizing a portable generator.

Outlet boxes are simple pass-through boxes that are mounted on or adjacent to a building and hard-wired to an existing power source. ESL's OutTap can be designed with or without a breaker based on your needs.



**400A OutTap
without Breaker**

Product Selection Information: 400A - 3200A

Example: OB8 - 0 - 480 - 311 - S - C (without Circuit Breaker)

OB8 - 800C - 480 - 311 - S - C (with Circuit Breaker)

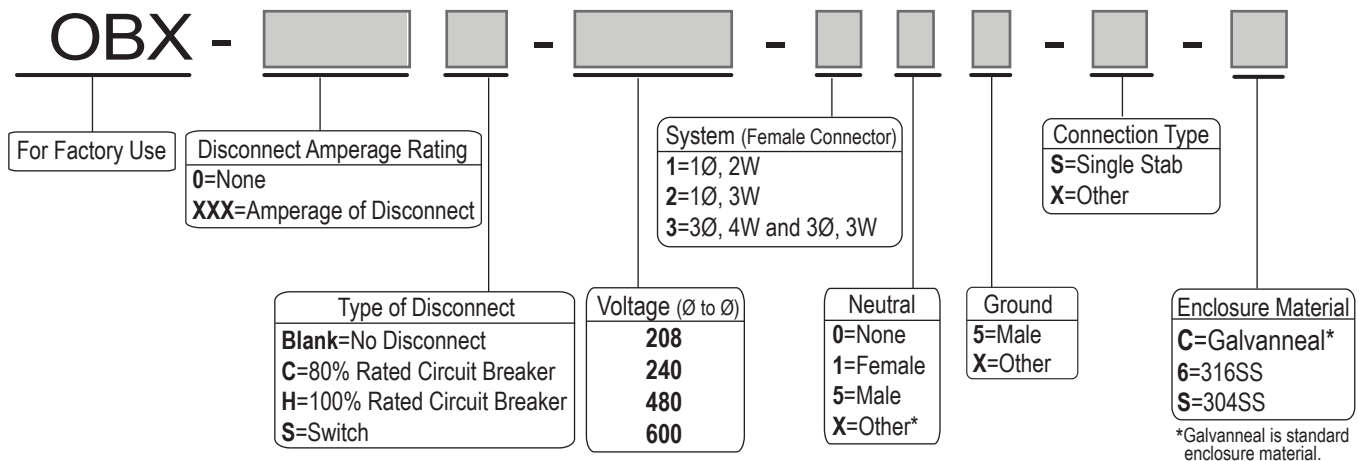

Typical Configurations • 400A - 3200A without a breaker

(For standard dimensions refer to corresponding TempTap amperage on pages 10 & 12)

Max Current Rating (Amps)	Model	Load Terminals Per Phase & Neutral	Ground Lug (Wire Range)	Cam-style Receptacle Size Per Phase & Neutral (Amps)	Ground Cam-style Receptacle Size (Amps)	Max Current Withstand Rating (KA)
400	OB4	(1) 1/2 -13x7/8" stud	(1) #6-250	(1) 400	(1) 400	22 (Single PH) 42 (3 PH)
800	OB8	Copper pad with (6) .53" holes on 1 3/4" V x 1" H	(1) #6-250	(2) 400	(1) 400	42
1200	OB12	Copper pad with (4) .53" holes on 1 3/4" V x 2" H; (2).44" holes on 1 3/8" V	(1) #6-250	(3) 400	(1) 400	42
1600	OB16	Copper pad with (4) .53" holes on 1 3/4" V x 2" H; (2).44" holes on 1 3/8" V	(1) #6-250	(4) 400	(1) 400	42
2000	OB20	Mech lugs accept (8) 300 - 800 kcmil	(6) #2AWG - 600 kcmil	(5) 400	(2) 400	42
2400	OB24	Mech lugs accept (8) 300 - 800 kcmil	(6) #2AWG - 600 kcmil	(6) 400	(2) 400	42
2800	OB28	Mech lugs accept (8) 300 - 800 kcmil	(6) #2AWG - 600 kcmil	(7) 400	(2) 400	42
3200	OB32	Mech lugs accept (8) 300 - 800 kcmil	(6) #2AWG - 600 kcmil	(8) 400	(2) 400	42

Other options available - consult the factory.

OutTap™

Outlet Box with Circuit Breaker

125A - 3200A

ESL's OutTap with Circuit Breaker includes a safety-interlocked door for safe connection and operation. All outlet boxes are UL 891 Listed and provide a quick and safe connection with color-coded female cam-style receptacles.

**UL/cUL
1008
LISTED**



**1600A OutTap
with Breaker**

OutTap Features

- Safety-interlocked door and dead front panel
- 400A rated color-coded cam-style connectors (male) for easy connections
- Type 3R double coated, cold-rolled steel enclosure (stainless steel, Type 3RX, & colors optional)
- Hinged, padlockable access door with door stoop
- UL /cUL 891 Listed up to 3000A

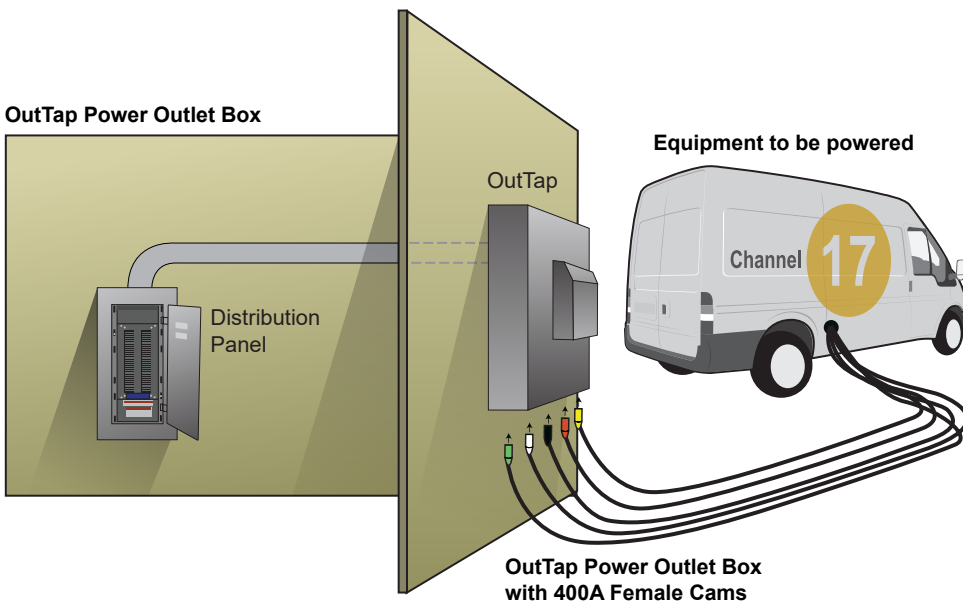

OutTap Single Line Diagram

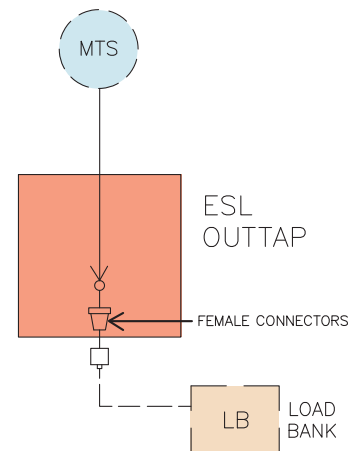

Typical Configurations with Breaker • 125A - 3000A

(For standard dimensions refer to corresponding StormSwitch amperage on pages 1 & 3)

Model	Current Rating (Amps)	Line Terminals (Wire Range)	Ground Lug (Wire Range)	Cam-style Receptacle Size (Amps)
OB4	400 max	(1) #2-600	(2) #6-250	400
OB8	300, 350, 400, 450, 500, 600, 700, 800	(3) 3/0-500	(2) #6-300	(2) 400
OB12	1200 max	(4) 3/0-500	(4) 1/0-750 (1) #2-600	(3) 400
OB16	1600 max	(4) 300 - 800	(9) #2-600	(4) 400
OB20	2000 max	(6) 300 - 800	(9) #2-600	(5) 400
OB24	2400 max	(8) 300 - 800	(9) #2-600	(6) 400
OB28	2800 max	(8) 300 - 800	(9) #2-600	(7) 400
OB32	3000 max	(8) 300 - 800	(9) #2-600	(8) 400

ReadyConnect™

Automatic Transfer Switch with Cams 30A - 1200A

ESL's ReadyConnect Automatic Transfer Switch (ATS) with Cams is UL/cUL1008 Listed from 30A to 400A and available up to 1200A. ReadyConnect provides the ability to proactively connect back-up power before planned outages. This ensures maintenance workers are not required to be on site for power to be switched from one source to another and then restored.

With quick connect cam-style connectors, ESL's ReadyConnect allows for an easy and safe, portable generator connection and operation for any commercial or industrial buildings.

Applications

- Banks/Financial Centers
- Water/Wastewater
- Manufacturing
- Financial Centers
- Petrochemical
- Healthcare Facilities
- Office buildings
- Educational Facilities

ReadyConnect Features

- Type 3R Double coated, cold-rolled steel enclosure with wrinkle gray RAL 7035 powdercoat (stainless steel & additional colors optional)
- Optional Thermostat, Dehumidistat and Heater
- Suitable for Use as Service Equipment (SUSE)
- Operating instructions silkscreened on deadfront
- Door and dead front panel for safe generator connection and operation
- Unit uses 3-pole ATS as standard (4-pole optional)
- 16 Series cam-lock connectors for easy portable generator connection
- Remote Start Stop Connections
- Quick connect solution for primary and alternative sources
- Aux contacts for remote monitoring

ReadyConnect Single Line Diagram

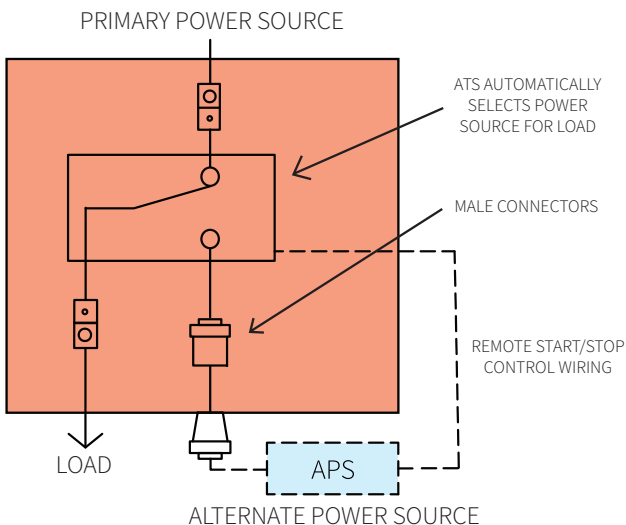

400A Automatic Transfer Switch with Cams



400A 480VAC Automatic Transfer Switch with Cams

Approvals

- UL/cUL 1008 Listed assembly
- UL 1691 Listed receptacles
- UL 1008 Listed molded case switch
- IBC 2015/ASCE 7-10 compliant

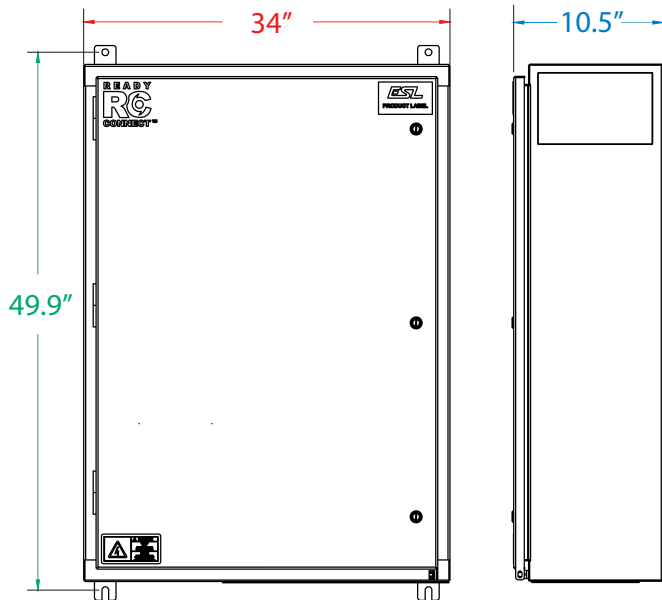

400A Automatic Transfer Switch with Cams

Note: Dimensions and weights are subject to change. Please verify with factory.

- Type 3R enclosure
- UL /cUL 1008 Listed Assembly



Thermostat, de-humidistat and heater



Remote start/stop connections



3-pole ATS as standard

ReadyConnect™ Connection to Portable Generator

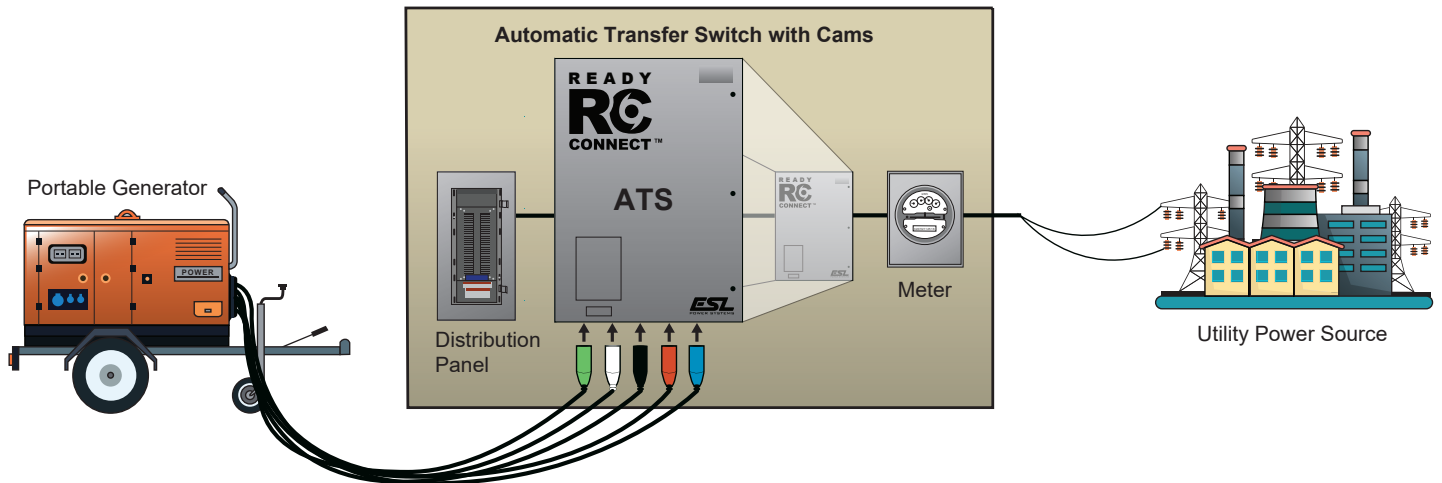

DualConnect™

Dual Purpose Docking Station UL 1008 Listed 400A - 5000A

For emergency backup system designs with either multiple or existing generators, ESL's UL 1008 Listed DualConnect – Dual Purpose Docking Station (DPDS) provides the flexibility needed to meet your design criteria.

ESL's Dual Purpose Docking Station offers the ability to connect a load bank and portable generator at the same time and is UL 1008 Listed from 400A to 5000A. The DualConnect is available in three different versions based on your design needs.

Applications

- Healthcare Facilities
- Data Centers
- Wastewater Lift Stations
- Financial Centers
- Emergency Operations Centers
- Airports
- Tunnels & Bridges

DualConnect Features

- Key Interlock with permanent generator and DPDS portable generator cable access door
- All cam lock connections located at the bottom of the unit for easy access and cable connection
- NEC700.3(f) and NEC 240.87 compliant
- Optional 1 breaker and 2 breakers available

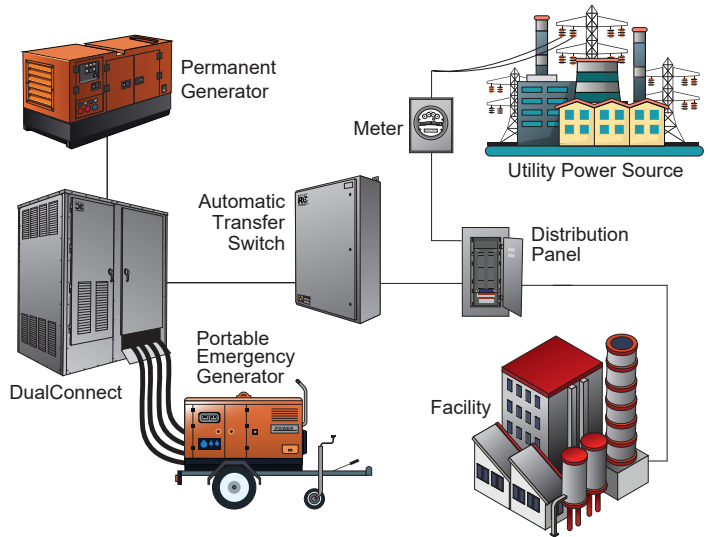
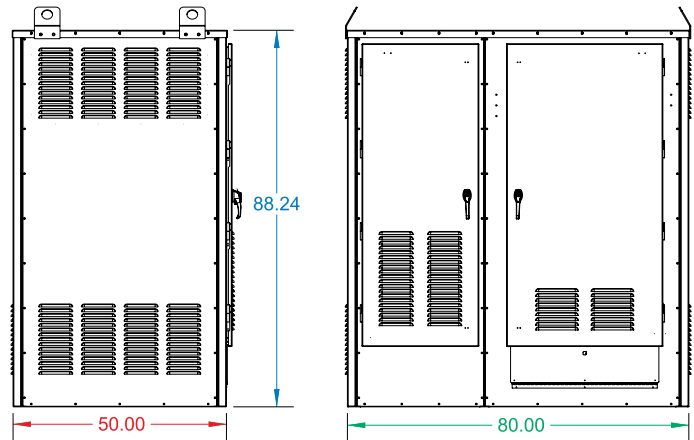

Diagram above represents DualConnect operating function



DualConnect

TWO Breakers

Provides overcurrent protection to the unit and disconnects for both the load bank and portable generator cams. The interlock between the permanent generator and temporary back up generator is accomplished by a key interlock between a designated breaker and the portable generator breaker in the DPDS



5000A DualConnect

All of ESL's DualConnect units with 2 breakers can be configured to meet NEC700.3(F) if required.

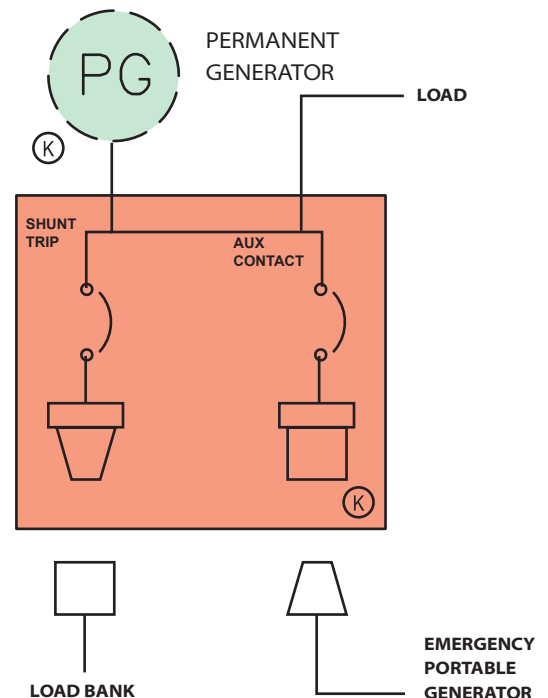

DualConnect

NO Breaker



Where all the controls and/or breakers are currently in the emergency power system.

The interlock between the permanent generator and temporary back up generator is accomplished by a key interlock between a designated breaker and the portable generator cable access door.

1200A DualConnect

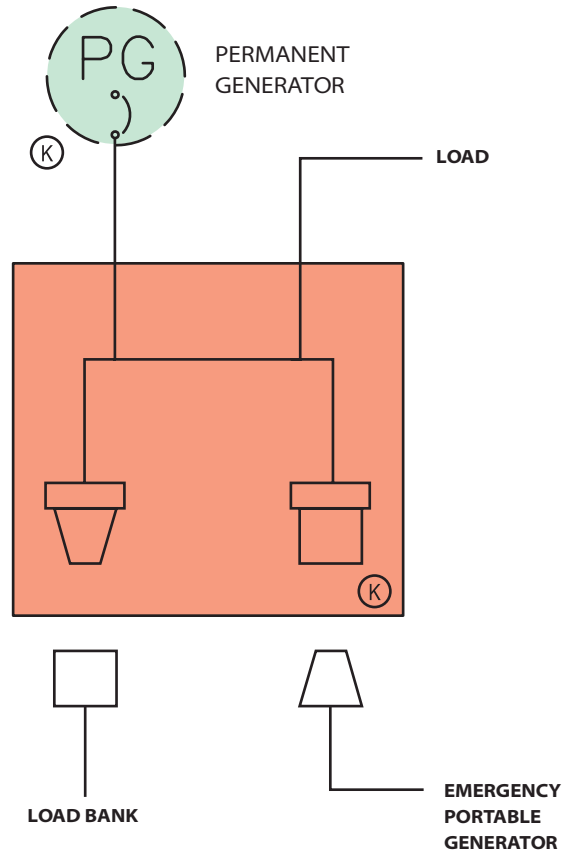
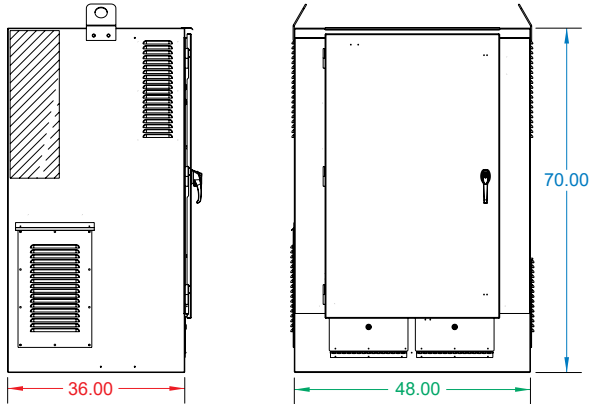

DualConnect

ONE Breaker



Provides overcurrent protection to the unit and disconnect for either the load bank or portable generator cans depending on the available emergency power system design.

The interlock between the permanent generator and temporary back up generator is accomplished by a key interlock between a designated breaker and the portable generator cable access door.

3000A DualConnect

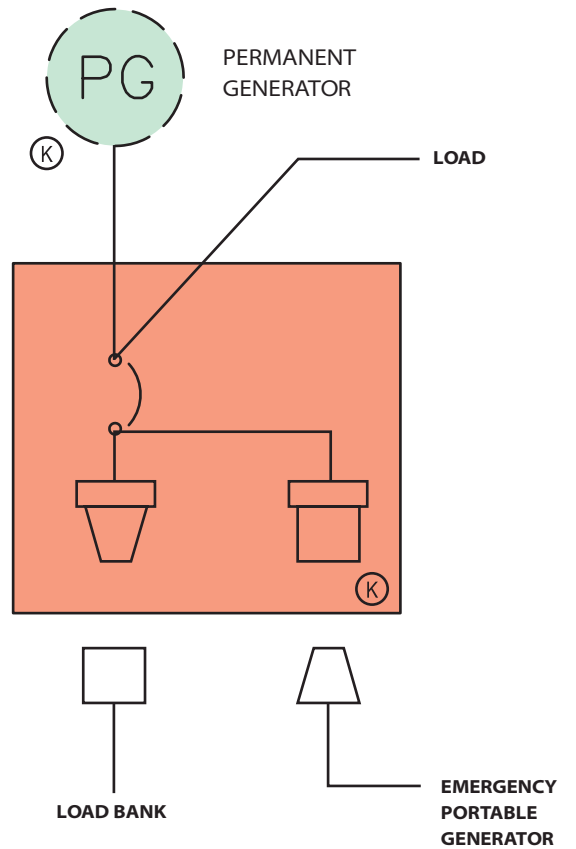
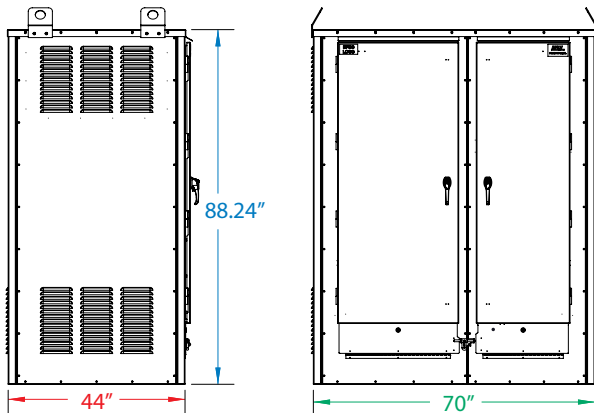

DirecTap™

Termination Cabinet (Junction Box)

100A - 1500A

UL 1773 LISTED



ESL's industrial grade DirecTap is a UL1773 Listed termination box. Equipped with power distribution blocks, these direct wire tap boxes are designed to make lug connections to permanently installed equipment such as an ATS, UPS, or supporting switchgear.

DirecTap enclosures are available in a variety of types ranging from Type 1-4X. ESL's termination boxes provide a permanent connection to emergency power systems for a variety of facilities, including refineries, pharmaceutical, food processing and manufacturing.

100A - 1500A DirecTap

DirecTap Features

- Terminal blocks or Power distribution blocks
- Various types of enclosures available
- Hinged, padlockable access door
- UL 1773 Listed

Applications

- Refineries
- Pharmaceutical
- Food Processing
- Manufacturing

Product Selection Information: 100A - 1500A

Example: DT0400 - 600 - 311 - CW4X

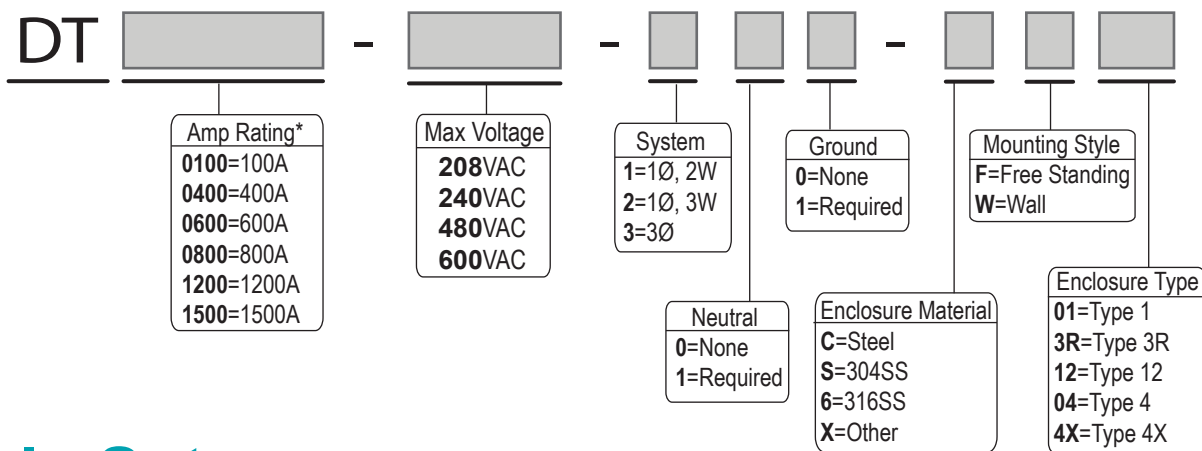

Cable Sets

208VAC - 480VAC - 600VAC

ESL offers cord assembly sets for our emergency power connection equipment in 208VAC, 480VAC and 600VAC color-coded configurations.

Each standard set is 25 feet of 4/0 UL Listed flexible welding cable and includes (3) phase cables, (1) ground cable and (1) neutral. Standard cables are factory wired with a 400A camlok female connector and a 400A camlok male connector.

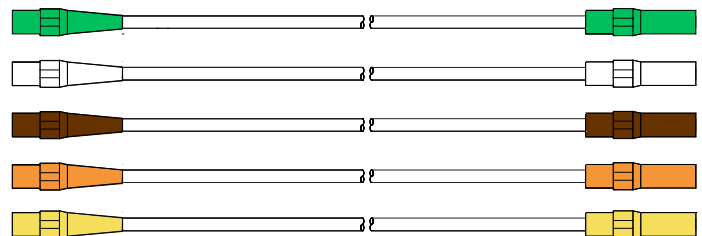

- One cable set is required per 400A increase
- Color configuration varies based on voltage rating
- Customer can specify custom lengths

Why UL 1008 Should Be Specified

When comparing NRTL Listings of different products, it is important to know what the appropriate UL standards are and how they apply to your specific application. You may not always be purchasing what you think you are. UL 1008 is specifically designed for transfer switch equipment. Products with a UL 1008 certification ensure the complete assembly is certified and has undergone rigorous testing to validate performance, safety, and reliability. Non-Automatic transfer switches that are Listed under the UL 1008 standard are evaluated in accordance with Articles 517-Health Care Facilities, 702-Optional Standby Systems of the National Electrical Code (ANSI/NFPA 70) and the National Fire Protection Association Standard for Health Care Facilities (ANSI/NFPA 99). The local inspection process by the AHJ is typically much easier when emergency power transfer switch equipment is UL 1008 Listed.

Frequently Asked Questions

What are the advantages and disadvantages of using a manual transfer switch with a portable generator versus an automatic transfer switch with a permanent generator?

The Advantages are:

- Significantly lower initial and lifetime cost
- No on-site fuel storage required
- No maintenance or standard periodic testing
- Easier installation – days instead of weeks
- Smaller size
- Portable generator can be rented or used at other facilities
- Does not require multiple permits that a permanent generator install would require

Disadvantages:

- Longer time before generator power is established

What is UL 1008 and how does it affect me?

Local building inspectors (AHJ) typically require all new electrical equipment installed in their jurisdiction to be “Listed” which means the equipment has been approved by Underwriter Laboratories or another recognized test lab. For standby systems that allow portable generator connection, UL 1008 is the proper standard for manual transfer use. If the equipment is not Listed, or if only the enclosure is Listed under UL 50, it may not be acceptable to the inspector.

Can't I just connect my generator directly to my panel?

Accidentally backfeeding the utility grid can be very dangerous. For a direct connection you would need a licensed electrician to be present anytime you needed to hook up your generator. There are other methods and products available for powering up from a portable generator, but the StormSwitch® is the best product available that combines the simplicity of cam-style connectors with a safety interlock device that prevents backfeeding the utility grid.

Can vandals open or steal the StormSwitch? Can they shut off my power?

Once installed, the device is always in use. The StormSwitch door can be padlocked, preventing unauthorized entry. The disconnect handles can be padlocked in the “OFF” position for further security. With a minor modification, the disconnect handles can also be padlocked in the “ON” position, however this is not recommended. For additional security the StormSwitch is equipped with a lockable handle cover to prevent unauthorized use.

Where can I make conduit penetrations on the StormSwitch?

Conduit line/load penetrations can be made around the top portion of the enclosure (top left, top right, top back, top top) and/or bottom left of the enclosure only. For the StormSwitch BeBe®, conduit line/load penetrations can only be made through the bottom left side of the enclosure.

Can the StormSwitch be Service Entrance Rated?

Yes, the StormSwitch has the option to be SUSE (Suitable for use as Service Entrance in the USA). This option should only be used when the StormSwitch is installed at the building service entrance.

I am in Texas. Can the StormSwitch survive the rain/heat/cold/bugs here?

The StormSwitch is a Type 3R enclosure. This means it is suitable for outdoors, and will protect components from rain. To ensure that insects, debris, and small animals do not enter the enclosure, ESL provides a hinged cover over the cam openings in the bottom of the enclosure that is locked “closed” when the door is shut.

What is the TripleSwitch®?

The TripleSwitch is designed to simplify and reduce the cost of load bank testing procedures. In addition, this unique 3-way manual transfer switch system provides a quick and completely safe way to supply power to the facility from a portable emergency standby generator if the permanent generator is offline.

Is it difficult to make the generator connection to the StormSwitch, TripleSwitch or TempTap™ product line?

No, each of these products utilize the industry standard 400A series 16 cam-style connectors. The cams on ESL's StormSwitch, TripleSwitch and TempTap are color-coded to the voltage, e.g. 480/277 are green, white, brown, orange and yellow.



ESL Power Systems, Inc. | eslpwr.com
2800 Palisades Drive | Corona, CA 92878
Tel: (800) 922-4188 | +1(951) 739-7000

